

# ***RACETIME 2***

## **User Manual**

The Racetime 2 System  
The Linkgate System  
Single Start and Group Start Program  
Simple Stopwatch Program

*Release. 2.10*

**MICRO  GATE**

Microgate S.r.l.  
Via Stradivari, 4  
I-39100 BOLZANO - ITALY

# *Index*

<b>THE RACETIME 2 SYSTEM.....</b>	<b>6</b>
<b>1 OVERVIEW .....</b>	<b>7</b>
1.1 RACETIME 2 .....	7
1.2 THE PRINTER .....	8
1.3 BACK VIEW .....	9
1.4 LINKGATE ENCODER.....	10
1.5 LINKGATE DECODER.....	11
1.6 CONNECTION BOX .....	12
<b>2 CONNECTION DIAGRAMS .....</b>	<b>13</b>
2.1 TIMING VIA CABLE .....	13
2.2 TIMING VIA RADIO.....	15
2.2.1 <i>Free along the Track</i> .....	16
2.2.2 <i>Radio-Encoder-Gate Connection</i> .....	17
2.2.3 <i>Radio-Encoder-Photocell Connection</i> .....	17
2.3 TIMING VIA RADIO.....	18
2.3.1 <i>Free along the track</i> .....	19
2.3.2 <i>EncRadio – Gate Connection</i> .....	20
2.3.3 <i>Radio-Encoder-Photocell Connection</i> .....	20
2.4 DISPLAYBOARD CONNECTION .....	21
2.5 MEASURING SPEED.....	22
2.6 CONNECTING THE BATTERY CHARGER.....	23
2.7 CONNECTORS .....	24
2.8 CONNECTION CABLES.....	25
<b>THE LINKGATE SYSTEM .....</b>	<b>30</b>
<b>3 INTRODUCTION .....</b>	<b>31</b>
<b>4 LINKGATE ENCODER : 3 FEATURES GUARANTEEING THE RELIABILITY OF RADIO TRANSMISSION .....</b>	<b>32</b>
4.1 DIGITAL TRANSMISSION OF IMPULSES.....	32
4.2 THE REPEAT FUNCTION .....	32
4.3 INTERNAL MEMORISATION OF EVENT TIMES.....	32
<b>5 USING YOUR LINKGATE ENCODER.....</b>	<b>33</b>
5.1 SELECTING THE CHANNEL .....	33
5.2 SELECTING THE TYPE OF SIGNAL.....	33
5.3 IMPULSE TRANSMISSION .....	33
5.4 THE REPEAT FUNCTION.....	34
5.5 CALCULATING A SPEED .....	34
5.6 HARDWARE RESETTING .....	34
5.7 RESETTING THE MEMORY .....	35
5.8 SYNCHRONIZATION.....	35

5.9	DOWNLOADING DATA onto RACETIME2.....	35
5.10	THE MODEM FUNCTION.....	36
5.11	MAINTENANCE.....	36
<b>PROGRAMS.....</b>		<b>38</b>
<b>6</b>	<b>INSTRUCTIONS FOR READING THE MANUAL.....</b>	<b>39</b>
<b>7</b>	<b>GENERAL INFORMATION.....</b>	<b>40</b>
7.1	FUNCTION AND CE KEY USE.....	41
7.2	NUMERICAL DATA INPUT.....	41
7.3	SWITCHING ON THE MACHINE.....	42
<b>SINGLE START AND GROUP START PROGRAM.....</b>		<b>44</b>
<b>8</b>	<b>SINGLE START AND GROUP START MODES.....</b>	<b>45</b>
<b>9</b>	<b>MAIN MENUS.....</b>	<b>47</b>
<b>10</b>	<b>TIMING.....</b>	<b>48</b>
10.1	INSERTION/CORRECTION FUNCTION.....	49
10.1.1	<i>Start number insertion/correction.....</i>	49
10.1.2	<i>Finish number insertion/correction.....</i>	50
10.1.3	<i>Use of keys <math>\uparrow\downarrow</math>.....</i>	50
10.1.4	<i>Turning the Autoskip function on and off.....</i>	51
10.1.5	<i>Skipped management (SkM).....</i>	51
10.1.6	<i>Editing or displaying intermediate times.....</i>	52
10.1.7	<i>Cancelling Skipped events memory.....</i>	52
10.1.8	<i>Activation/disactivation of automatic assignment of finishes and intermediate times on and off.....</i>	52
10.1.9	<i>Returning to the main menu.....</i>	53
10.1.10	<i>Returning to the main menu during timing.....</i>	53
10.2	MANAGEMENT OF EVENTS.....	54
10.2.1	<i>Displaying starts.....</i>	54
10.2.2	<i>Finishes management.....</i>	55
10.2.3	<i>Intermediate time management.....</i>	57
10.2.4	<i>Displaying speeds transmitted by the LINKGATE Encoder.....</i>	58
10.2.5	<i>Display of average speeds.....</i>	58
10.2.6	<i>LCK key use.....</i>	59
<b>11</b>	<b>INTERPRETATION OF PRINTED DATA DURING TIMING.....</b>	<b>60</b>
<b>12</b>	<b>GROUP MANAGEMENT.....</b>	<b>62</b>
12.1	RANKINGS FOR FINISH TIMES, INTERMEDIATE TIMES AND SPEED.....	64
12.1.1	<i>Viewing on the screen.....</i>	65
12.1.2	<i>Printing the ranking.....</i>	65
12.2	INTERMEDIATE TIME RANKINGS.....	66
12.3	SPEED RANKINGS.....	67
12.4	PRINTING EVENT TIMES, NP, NF, DISQUALIFIED, SKIPPED.....	68
<b>13</b>	<b>AUTOMATIC STARTS.....</b>	<b>69</b>
<b>14</b>	<b>DISQUALIFICATIONS/REINSTATEMENTS.....</b>	<b>70</b>
<b>15</b>	<b>SYNCHRONIZATION.....</b>	<b>71</b>
<b>16</b>	<b>OFF-LINE DATA TRANSMISSION.....</b>	<b>72</b>
<b>17</b>	<b>SYSTEM CONFIGURATION.....</b>	<b>73</b>
17.1	RACETIME configuration.....	73

17.1.1	<i>Time display mode</i> .....	73
17.1.2	<i>Event times printout</i> .....	73
17.1.3	<i>Automatic finish search</i> .....	73
17.1.4	<i>Net time print mode</i> .....	73
17.1.5	<i>Maximum time</i> .....	73
17.1.6	<i>Measurement accuracy</i> .....	73
17.1.7	<i>Modifying 'dead' times</i> .....	74
17.1.8	<i>Activating the LCK key</i> .....	74
17.1.9	<i>LINKGATE channel</i> .....	74
17.1.10	<i>Setting of serial transmission parameters</i> .....	75
17.1.11	<i>Activation/disactivation of the printer and of acoustic signalling when keys are pressed</i> .....	75
17.1.12	<i>Initialization of configuration</i> .....	75
17.2	SKITEST CONFIGURATION .....	76
17.2.1	<i>'Radio' speed base length</i> .....	76
17.2.2	<i>'Average' speed base length</i> .....	76
17.2.3	<i>Speed measurement unit</i> .....	76
17.2.4	<i>Temperature and humidity probe tests</i> .....	77
17.3	DISPLAYBOARD CONFIGURATION .....	78
17.3.1	<i>Displayboard type</i> .....	78
17.3.2	<i>Displayboard number</i> .....	78
17.3.3	<i>Advertising</i> .....	78
<b>18</b>	<b>OTHER FUNCTIONS</b> .....	<b>79</b>
18.1	RECHARGING BATTERIES .....	79
18.1.1	<i>Low batteries warning</i> .....	80
18.2	MEMORY LIMITS .....	80
18.3	RECEIVING DATA FROM LINKGATE .....	81
<b>19</b>	<b>RADIO SIGNAL QUALITY</b> .....	<b>83</b>
19.1	TIME CALCULATOR.....	84
	<b>SIMPLE STOPWATCH PROGRAM</b> .....	<b>86</b>
<b>20</b>	<b>SIMPLE STOPWATCH PROGRAM</b> .....	<b>87</b>
<b>21</b>	<b>TIMING</b> .....	<b>89</b>
<b>22</b>	<b>SETTING INITIAL TIME (START TIME)</b> .....	<b>91</b>
<b>23</b>	<b>VIEWING OF MEMORISED TIMES</b> .....	<b>92</b>
<b>24</b>	<b>DISPLAY OF TIMES ON THE MICROGATE ALPHANUMERIC DISPLAYBOARD</b> .....	<b>92</b>
<b>25</b>	<b>DATA TRANSMISSION</b> .....	<b>93</b>
<b>26</b>	<b>SYSTEM CONFIGURATION</b> .....	<b>94</b>
26.1	Racetime CONFIGURATION .....	94
26.1.1	<i>Measurement accuracy</i> .....	94
26.1.2	<i>Modifying 'dead' times</i> .....	94
26.1.3	<i>LINKGATE channel</i> .....	94
26.1.4	<i>Setting of serial transmission parameters</i> .....	96
26.1.5	<i>Activation/deactivation of the printer and of acoustic signalling when the keys are pressed</i> .....	96
26.1.6	<i>Initialization configuration</i> .....	96

26.2	Setting the length for speed calculation.....	97
26.3	DISPLAYBOARD CONFIGURATION .....	98
26.3.1	<i>Displayboard type</i> .....	98
26.3.2	<i>Number of displayboards</i> .....	98
26.3.3	<i>Advertising</i> .....	98
<b>27</b>	<b>OTHER FUNCTIONS .....</b>	<b>99</b>
27.1	RADIO SIGNAL QUALITY .....	99
27.2	time calculator .....	100
27.3	Recharging batteries .....	101
27.3.1	<i>Low batteries warning</i> .....	102
<b>APPENDIX</b>	<b>.....</b>	<b>105</b>
<b>28</b>	<b>TECHNICAL DATA .....</b>	<b>106</b>
<b>29</b>	<b>RACETIME2 TRANSMISSION PROTOCOL .....</b>	<b>108</b>
2.1	BINARY TRANSMISSION .....	108
29.1	ASCII TRANSMISSION .....	110
29.2	ON-LINE transmission during timing .....	112
<b>30</b>	<b>DATA FORMAT FOR THE TRANSFER OF DATA STORED IN THE LINKGATE ENCODER</b>	<b>113</b>
30.1	HEADER .....	113
30.2	DATA FRAME .....	113
30.3	SERIAL PORT SETTING .....	113
<b>31</b>	<b>PROBLEMS AND REMEDIES .....</b>	<b>114</b>

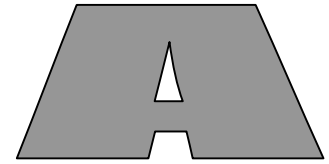

# **THE RACETIME 2 SYSTEM**

# 1 Overview

## 1.1 RACETIME 2

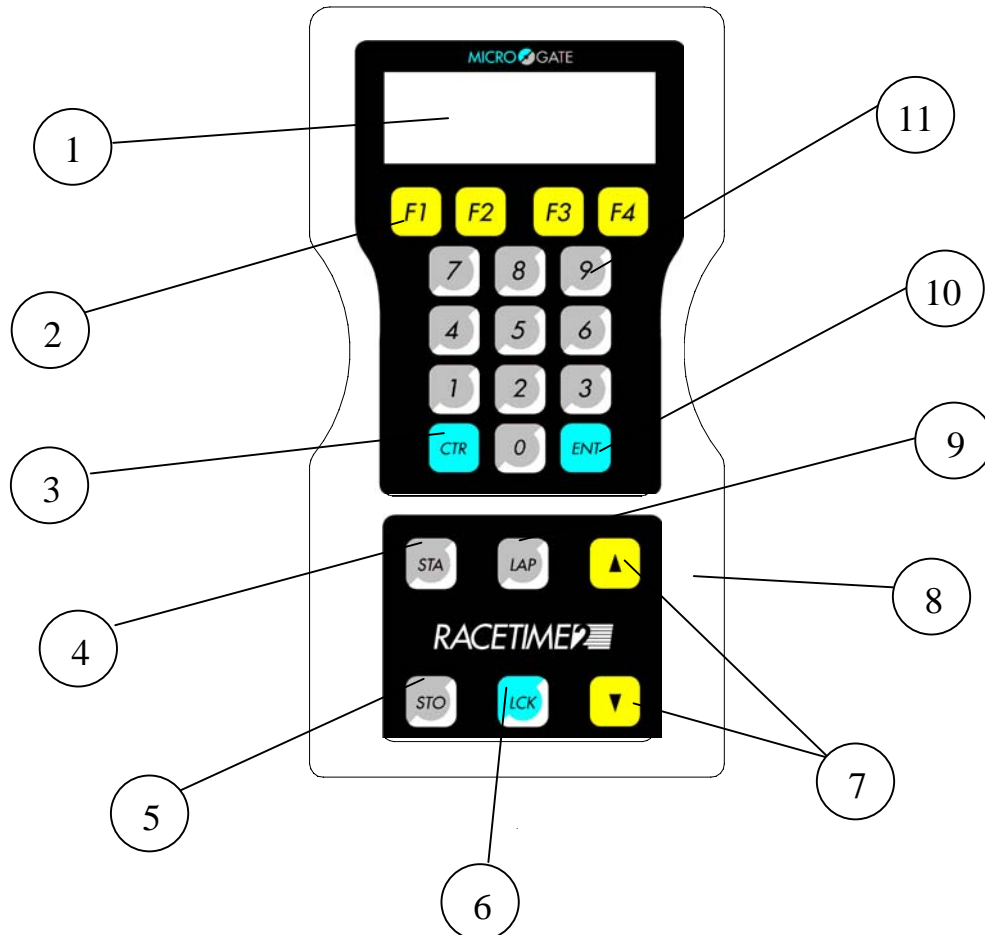

Fig. 1

1. Alphanumeric display (4 lines, 20 columns) with a range width of  $-30\text{ C} +70\text{ C}$
2. Function keys (F1,F2,F3,F4)
3. CE key (control/paper feed)
4. START key
5. STOP key
6. LOCK key
7. Arrow  $\uparrow\downarrow$  (running through times)
8. Case in ABS
9. LAP key
10. ENTER key
11. Numeric keyboard (0..9)

## 1.2 THE PRINTER

Inserting the printer

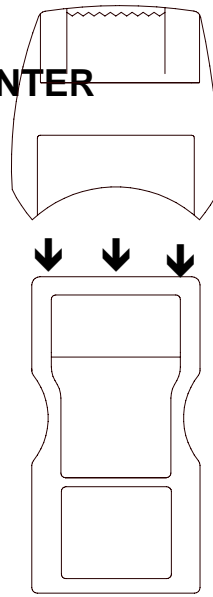
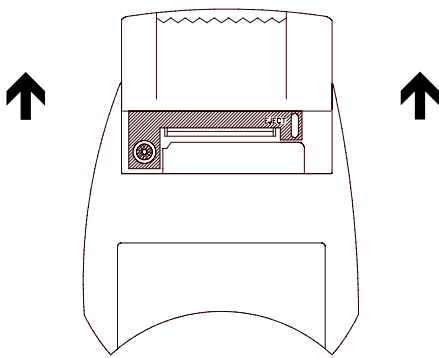
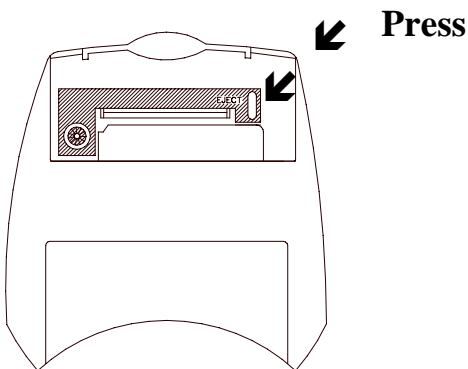

Fig. 2

Changing the printer cartridge



Opening the printer compartment



Press to remove printing cartridge

Fig. 3

Changing the paper roll

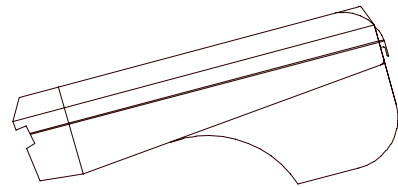

The printer

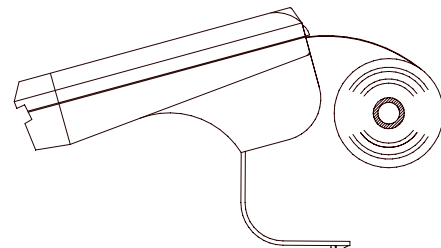

Opening paper roll compartment

Fig. 4



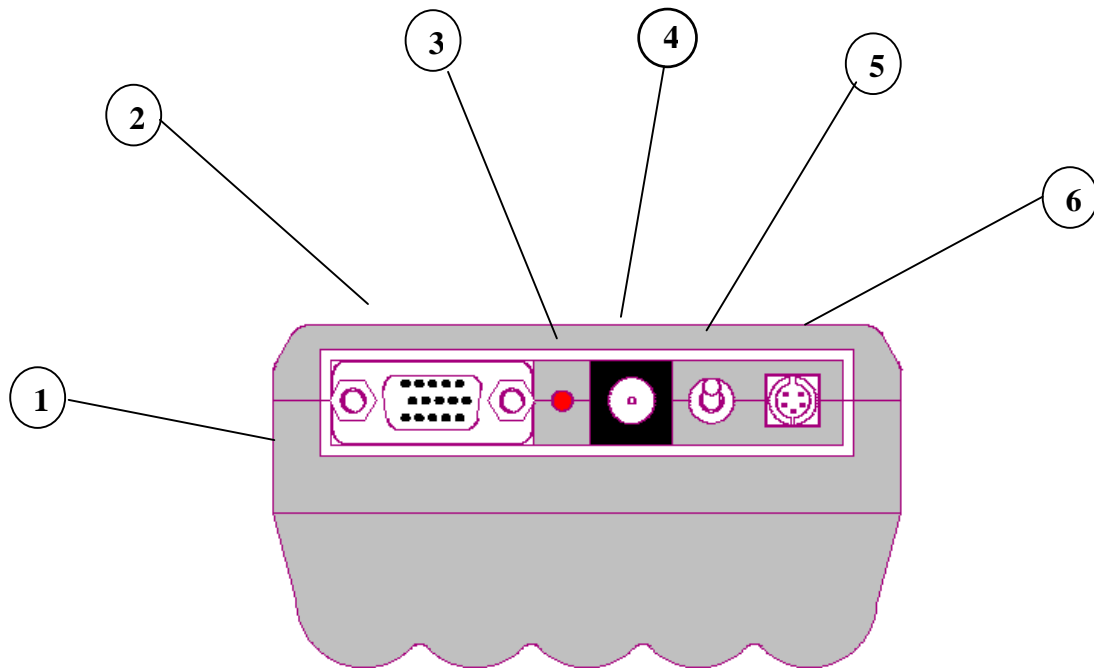

*Fig. 5*

### 1.3 BACK VIEW

1. Case in ABS
2. 15 pole female CANNON panel connector
3. Red LED
4. Power point for battery charger
5. ON/OFF switch
6. 5 pole male panel connector

### 1.4 LINKGATE ENCODER

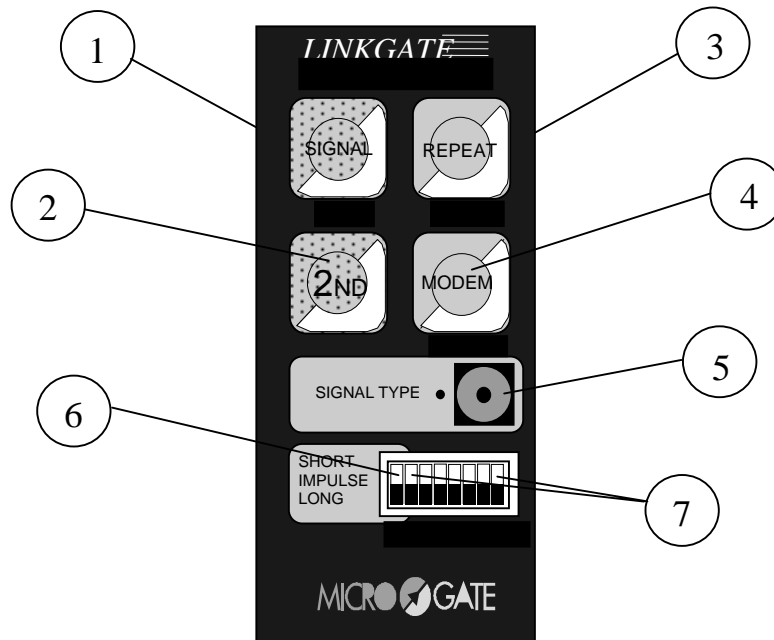

Fig. 6

1. SIGNAL key
2. SECOND FUNCTION (2ND) key
3. REPEAT key
4. MODEM key
5. Selector for transmitted signal type (Start, Lap, Stop)
6. Selector for transmitted signal redundancy (High, short signal – Low, long signal)
7. Selector for transmission channel (Dip Switch)

Top

Bottom

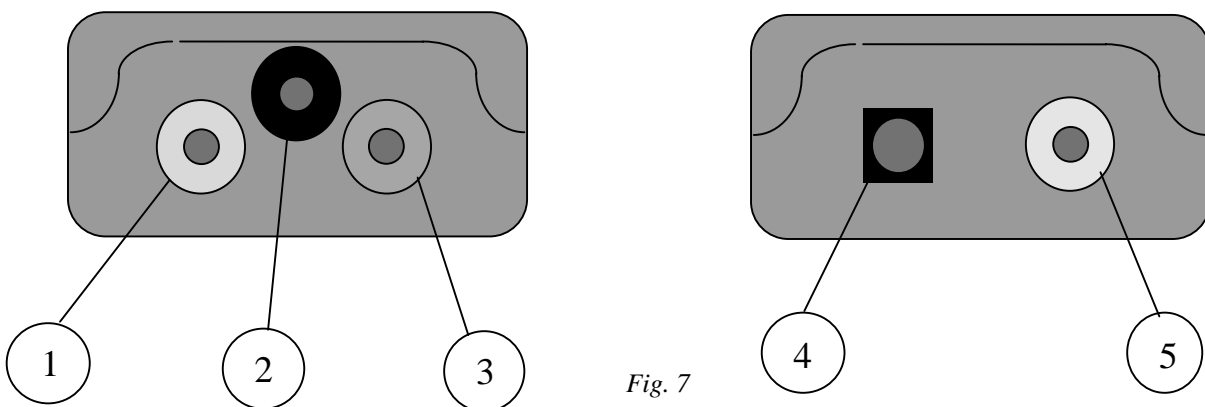

Fig. 7

- |  |                     |
|--|---------------------|
| 1. SPEED input   | (RED banana jack)   |
| 2. GROUND  | (BLACK banana jack) |
| 3. SIGNAL input  | (GREEN banana jack) |
| 4. Power point for radio connection and serial data download | (BLU banana jack)   |
| 5. MODEM input   | (BLU banana jack)   |

## 1.5 LINKGATE DECODER

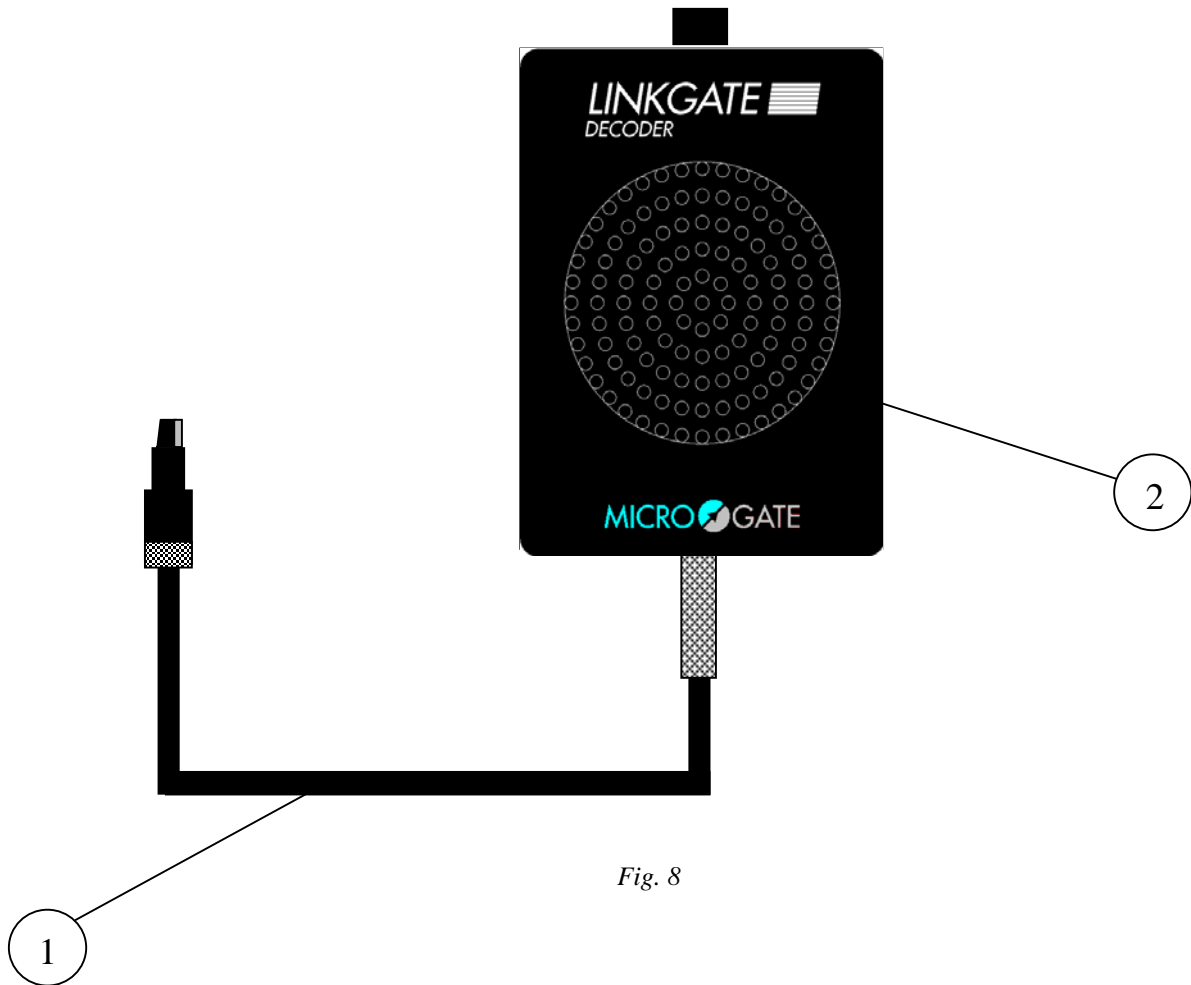

Fig. 8

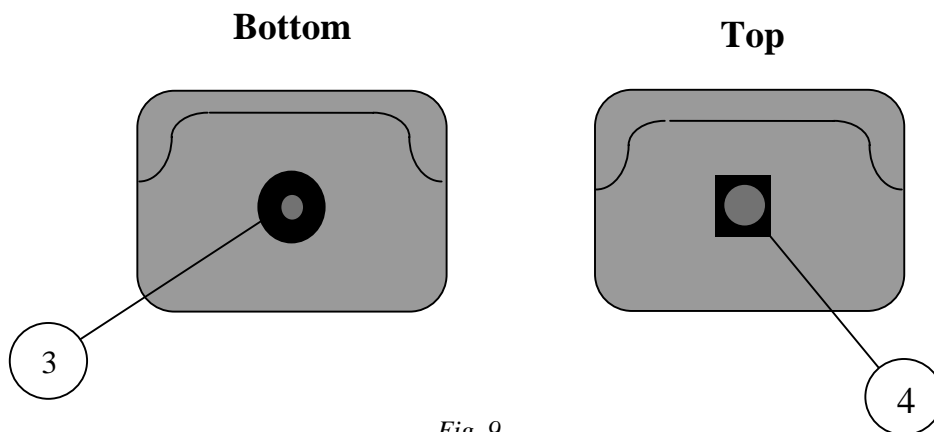

Fig. 9

1. Connection cable for Racetime2 (female 5 pole movable connector)
2. Loudspeaker
3. Cable output to connect with Racetime2
4. 3 pole male connector

## 1.6 CONNECTION BOX

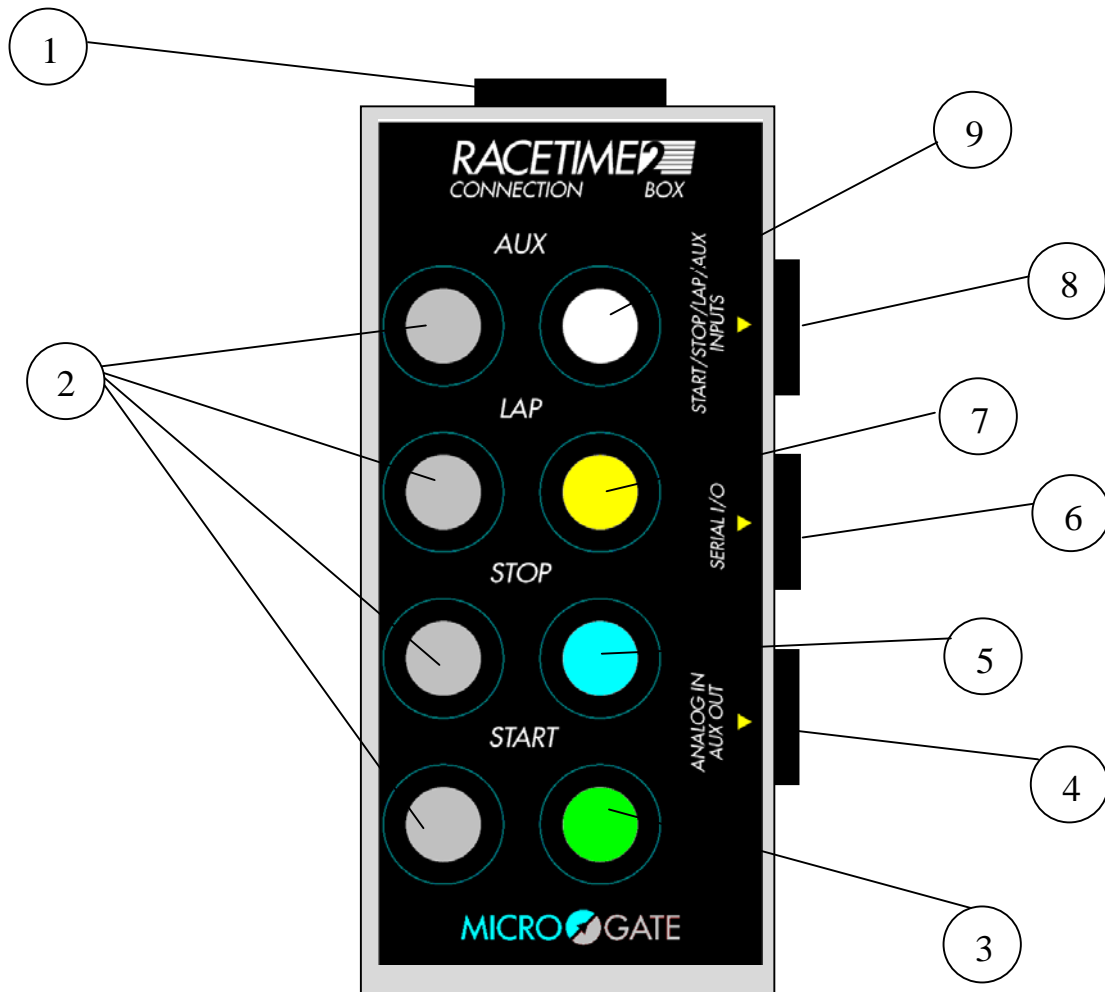

Fig. 10

1. 15 pole female CANNON panel connector to connect to Racetime2
2. GROUND banana jack (COMMON)
3. START banana jack
4. 6 pole Amphenol connector for inputs (START, STOP, LAP, AUX)
5. STOP banana jack
6. 6 pole Amphenol connector for serial inputs/outputs
7. LAP banana jack
8. 6 pole Amphenol connector for analogic inputs and auxiliary outputs
9. AUX banana jack

## 2 CONNECTION DIAGRAMS

### 2.1 TIMING VIA CABLE

Gate and photocell connected to connection box with the photocell powered by Racetime 2

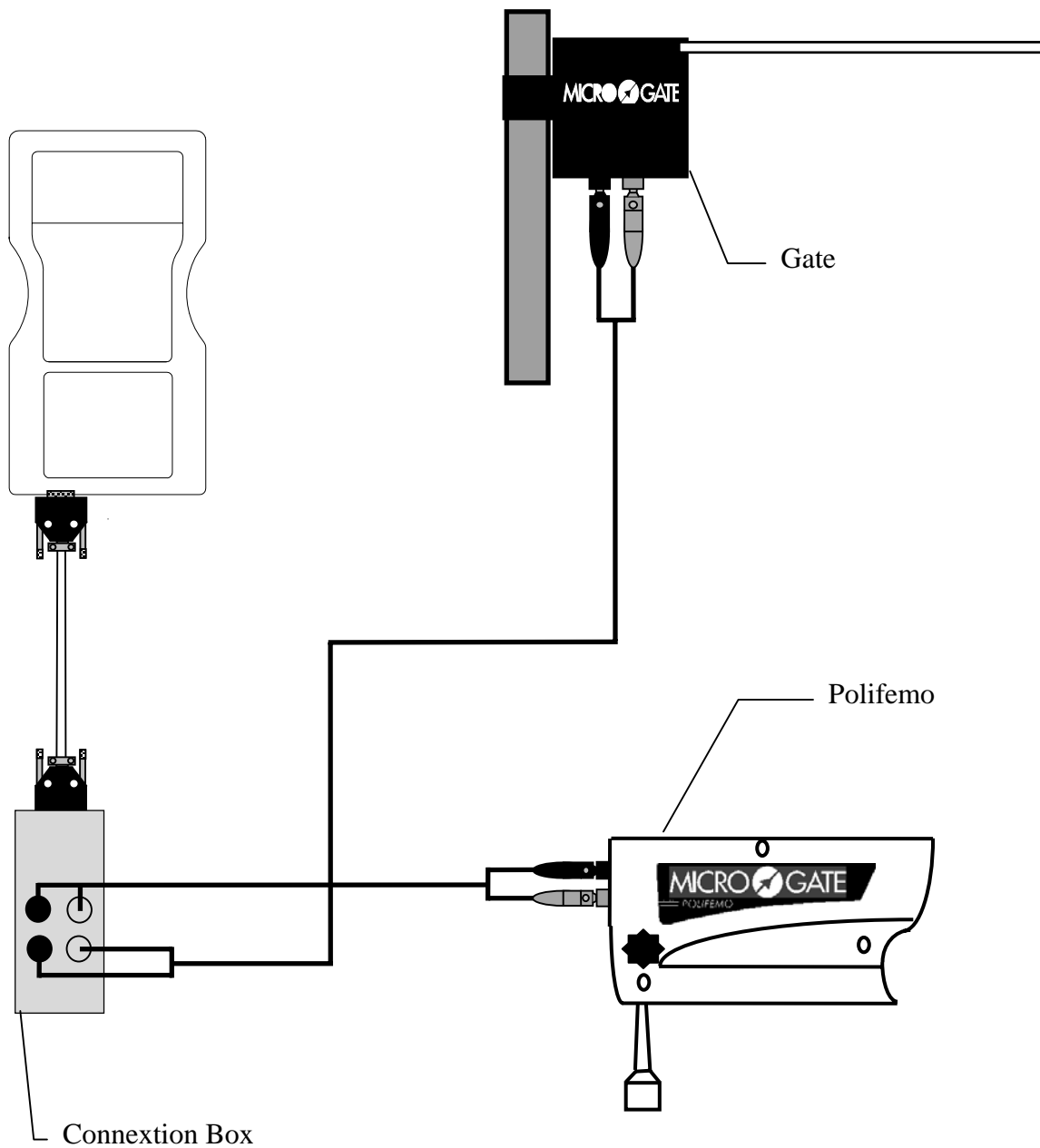
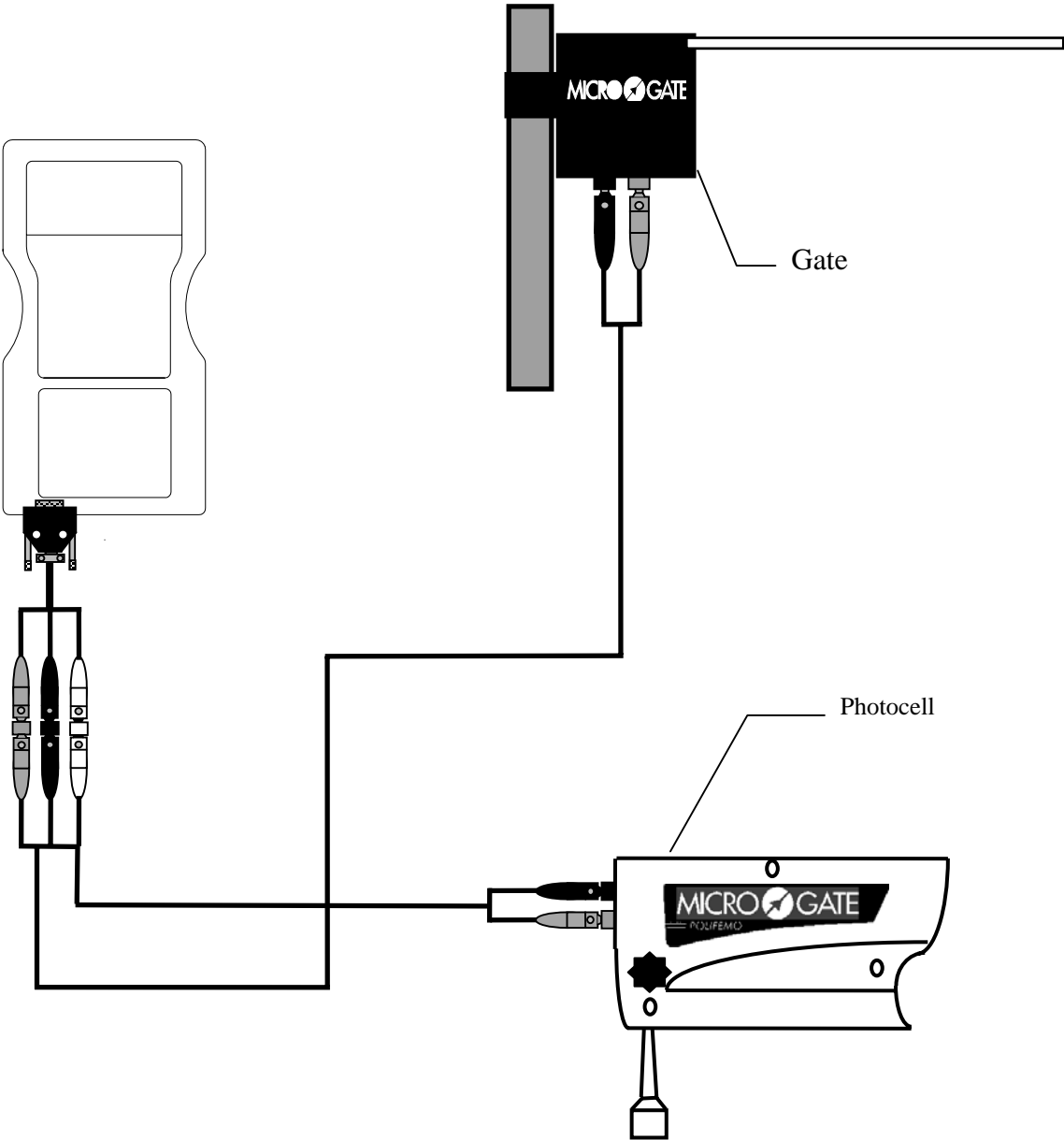

Fig. 11

**TIMING VIA CABLE**

**Gate and photocell connected to connection box with externally powered photocell**



*Fig. 12*

## 2.2 TIMING VIA RADIO

### Taking data at finish

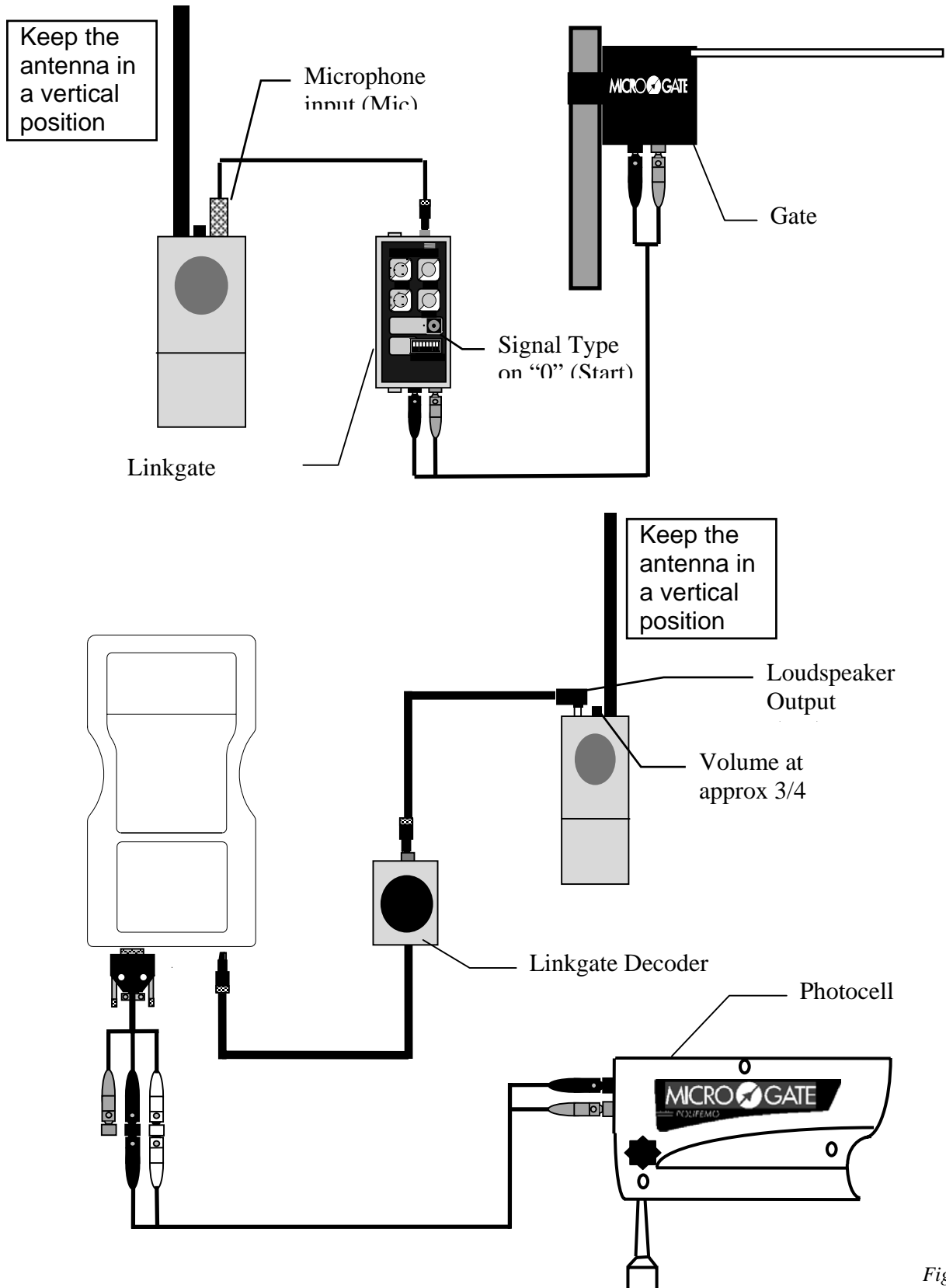
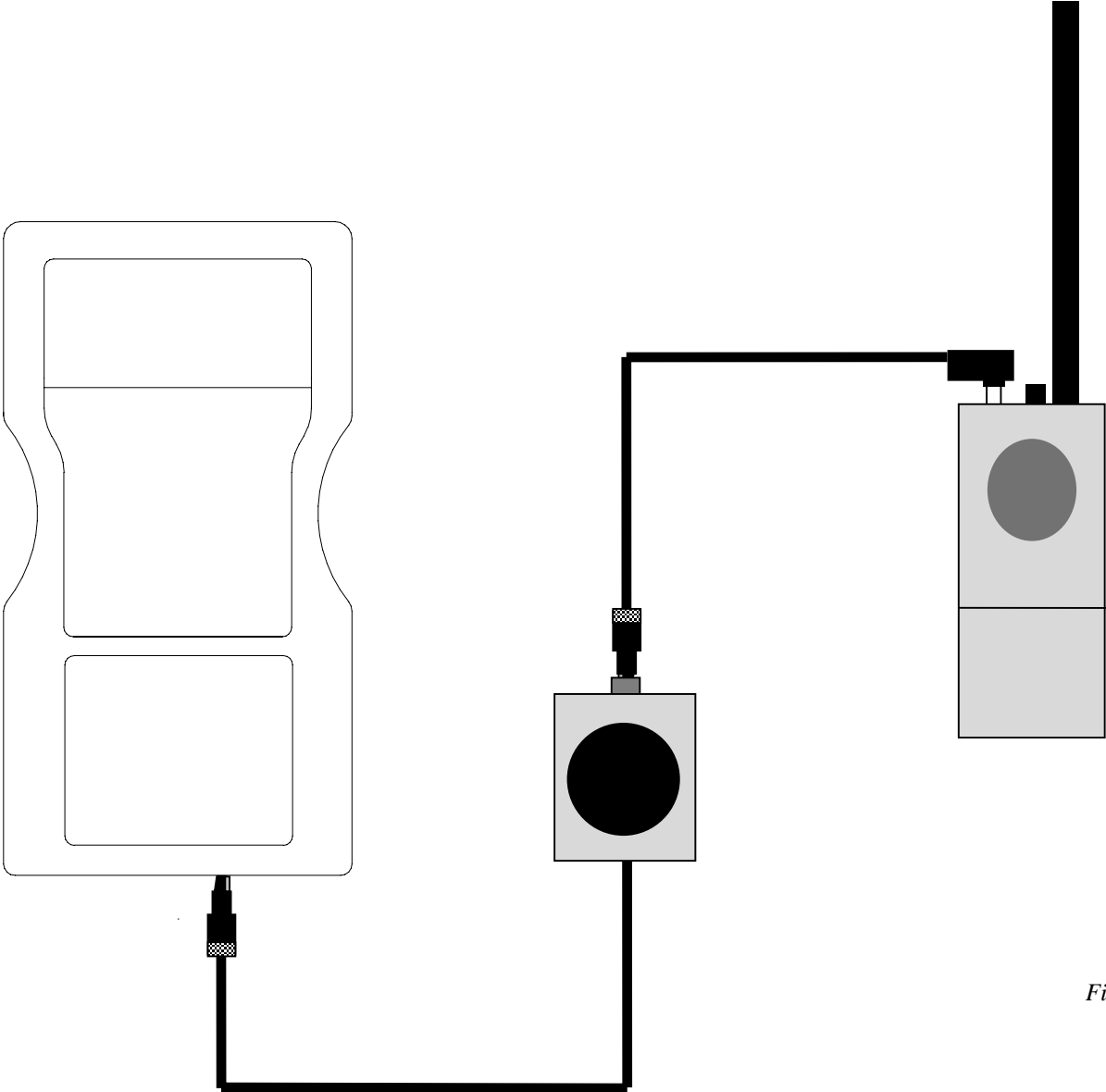

Fig. 13

**2.2.1 Free along the Track**

**Taking data from anywhere along the track**



*Fig. 14*



**2.2.2 Radio-Encoder-Gate Connection**

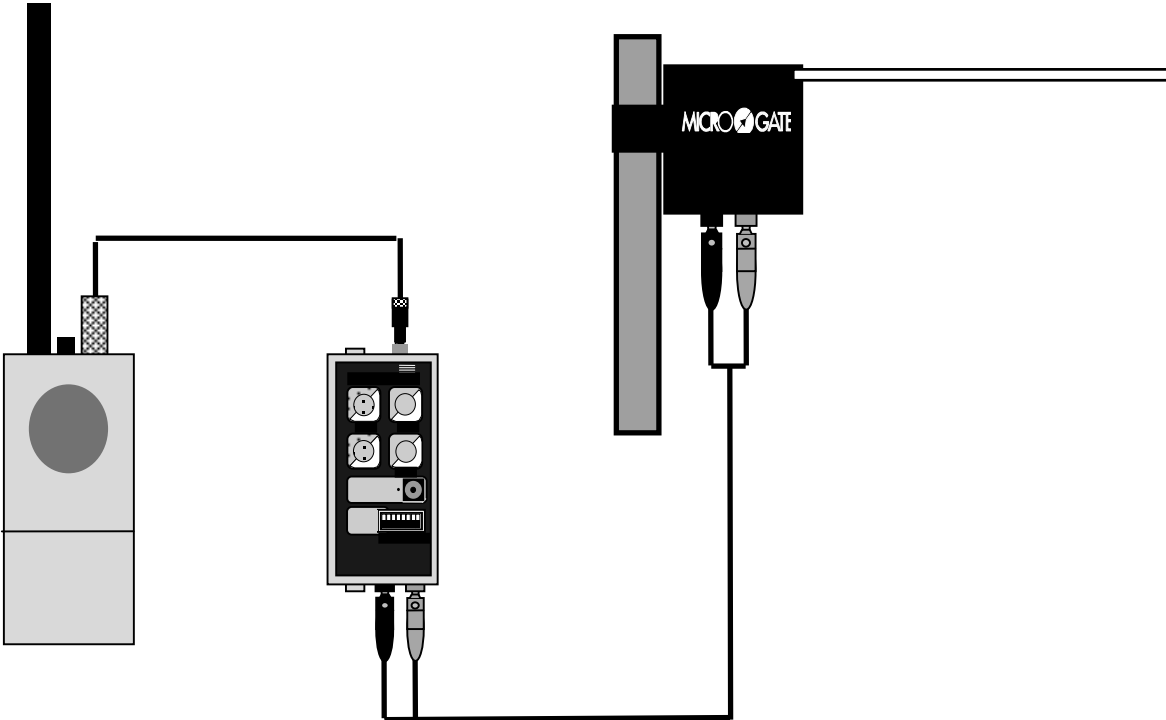

Fig. 15

**2.2.3 Radio-Encoder-Photocell Connection**

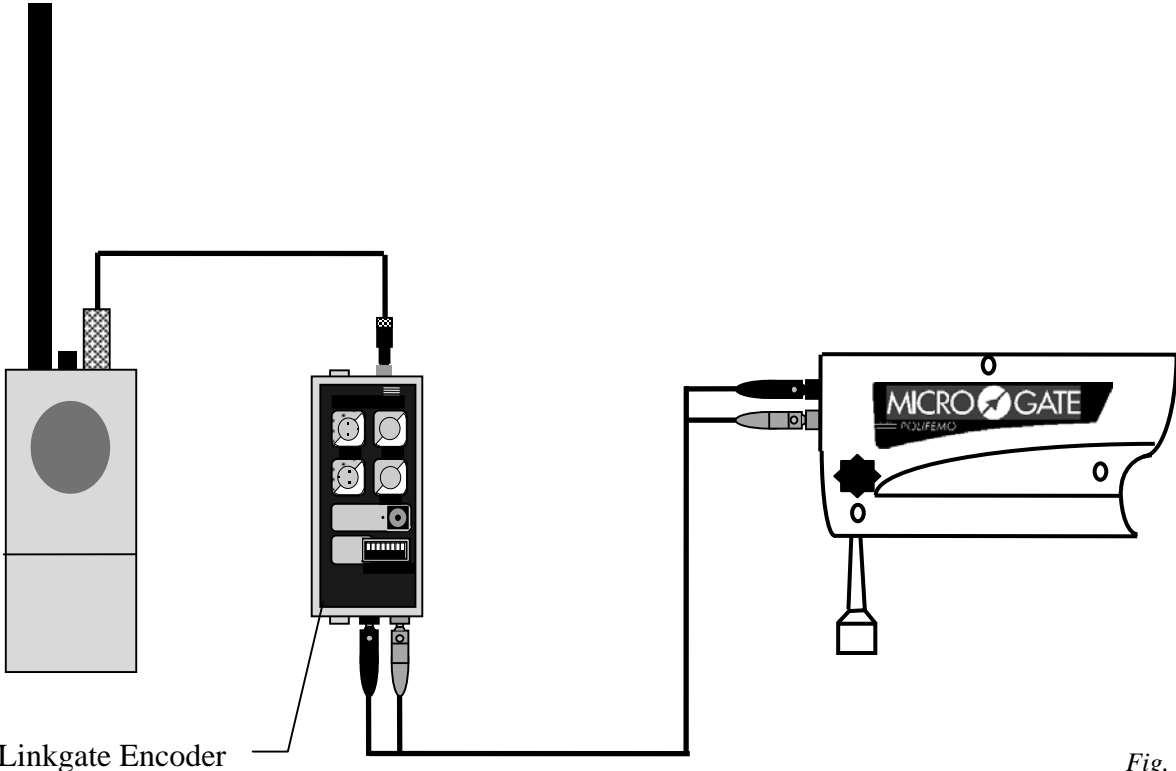

Fig. 16

### 2.3 TIMING VIA RADIO

Fig. 17

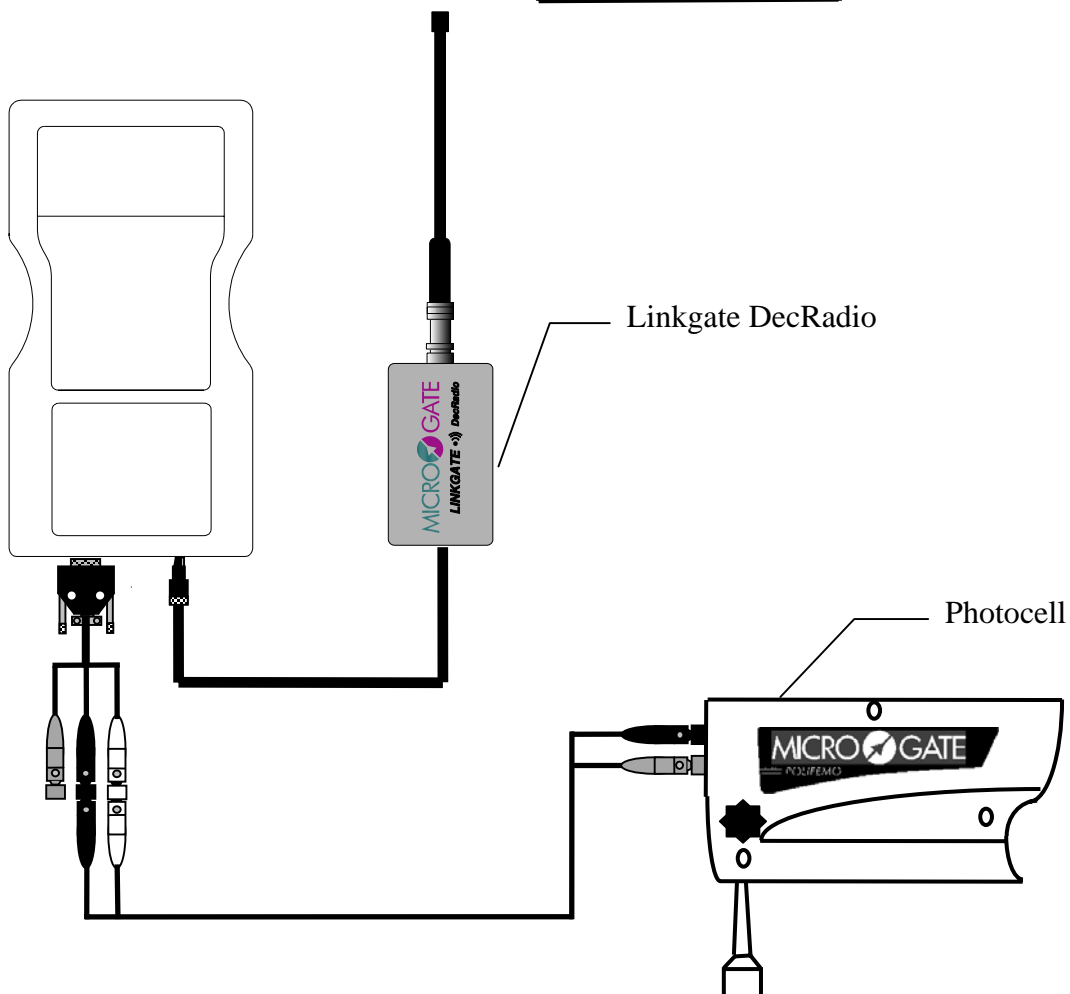
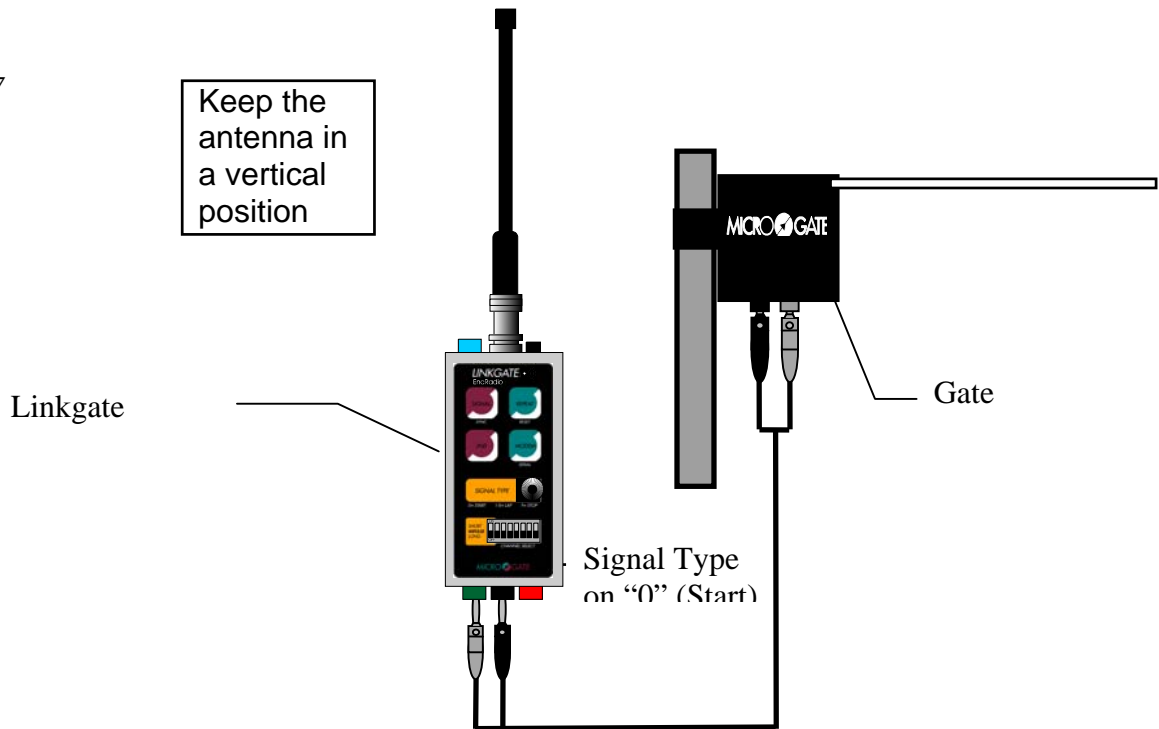

Fig. 18

**2.3.1 Free along the track**

**Taking data anywhere along the track**

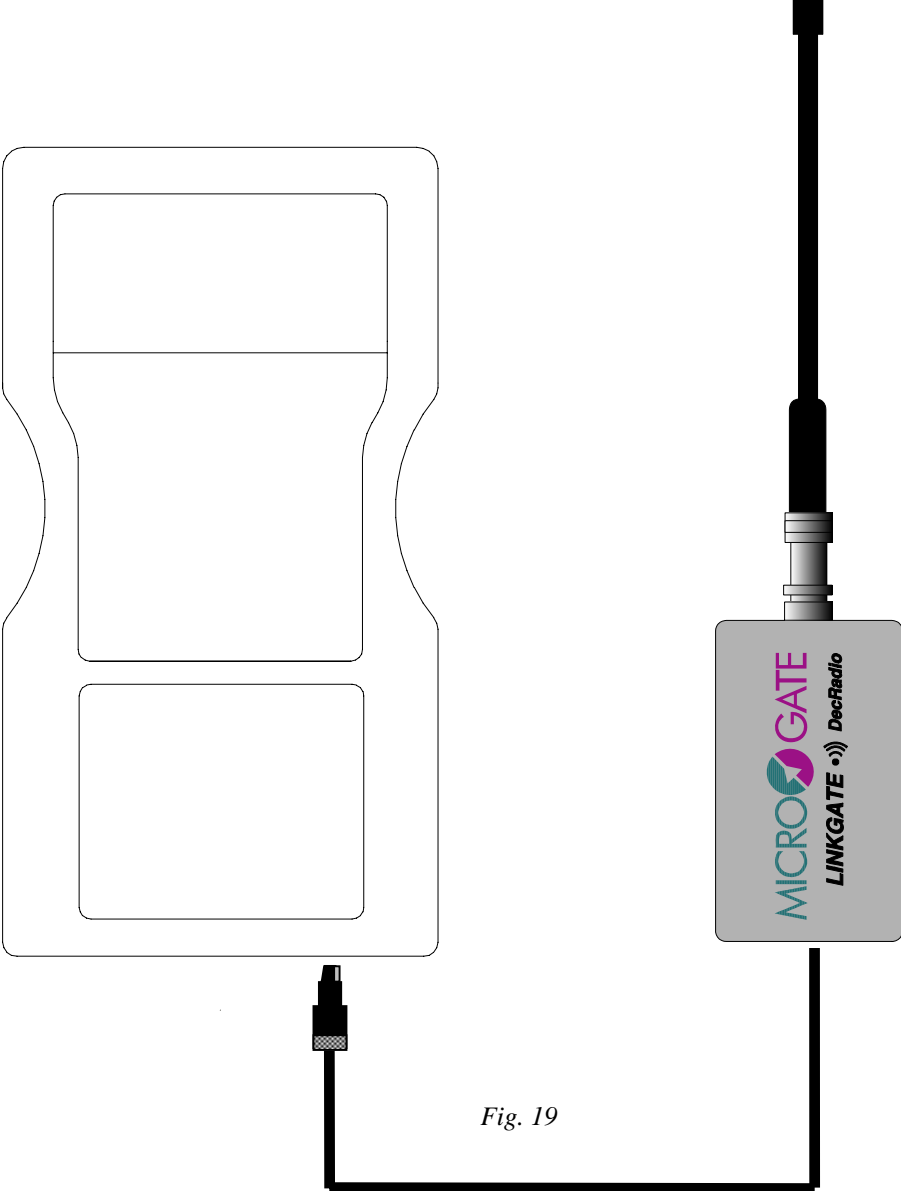

Fig. 19

### 2.3.2 EncRadio – Gate Connection

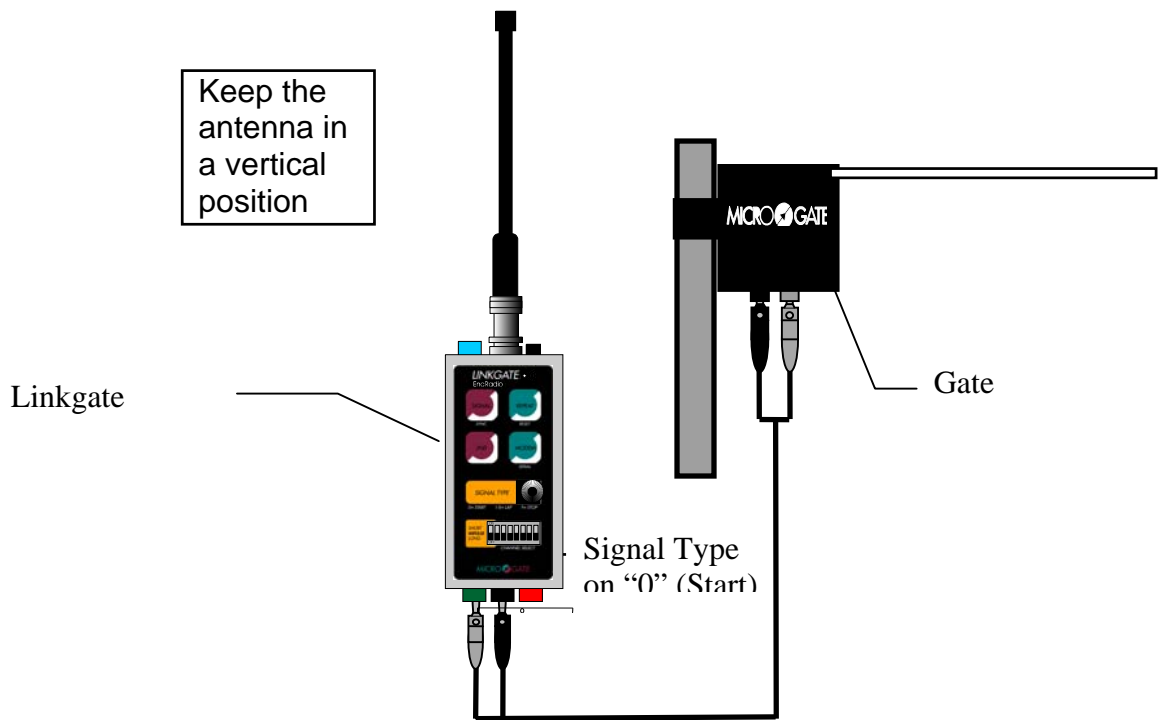
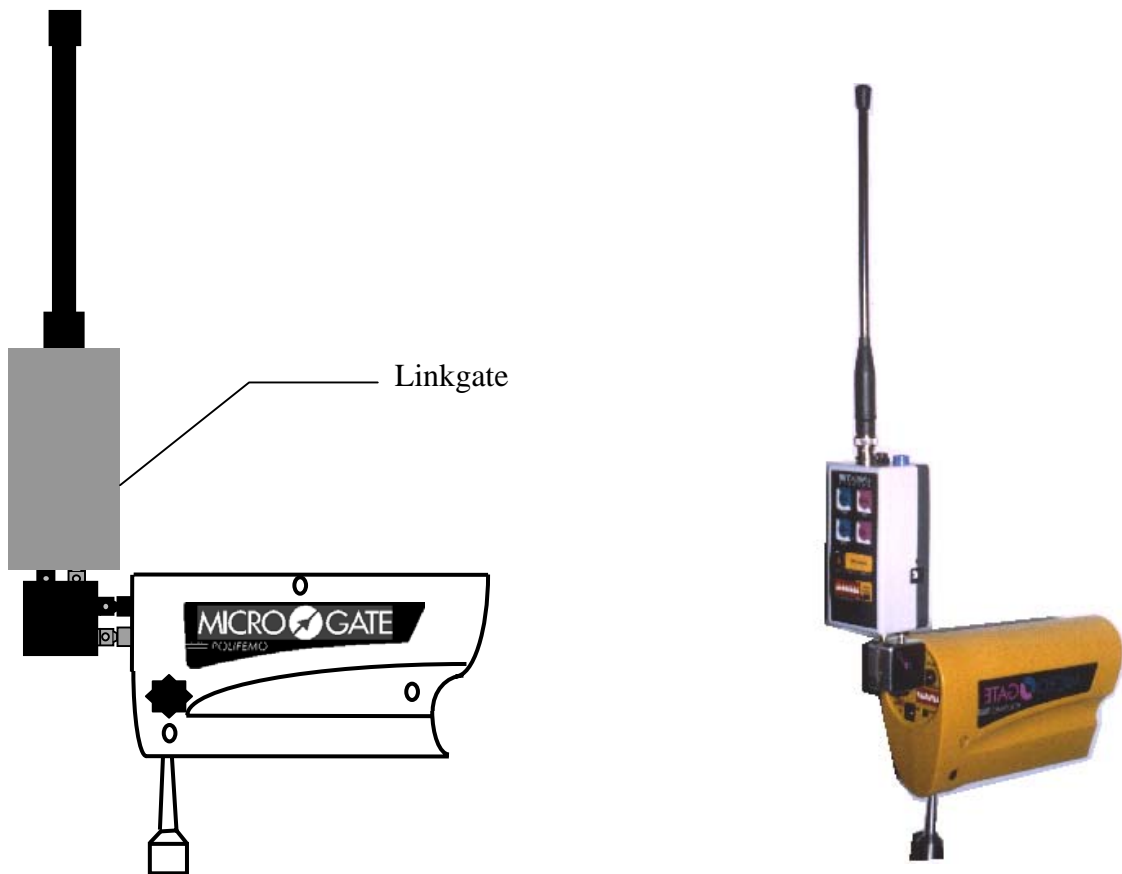

Fig. 20

### 2.3.3 Radio-Encoder-Photocell Connection

Fig. 21



## 2.4 DISPLAYBOARD CONNECTION

Fig. 22

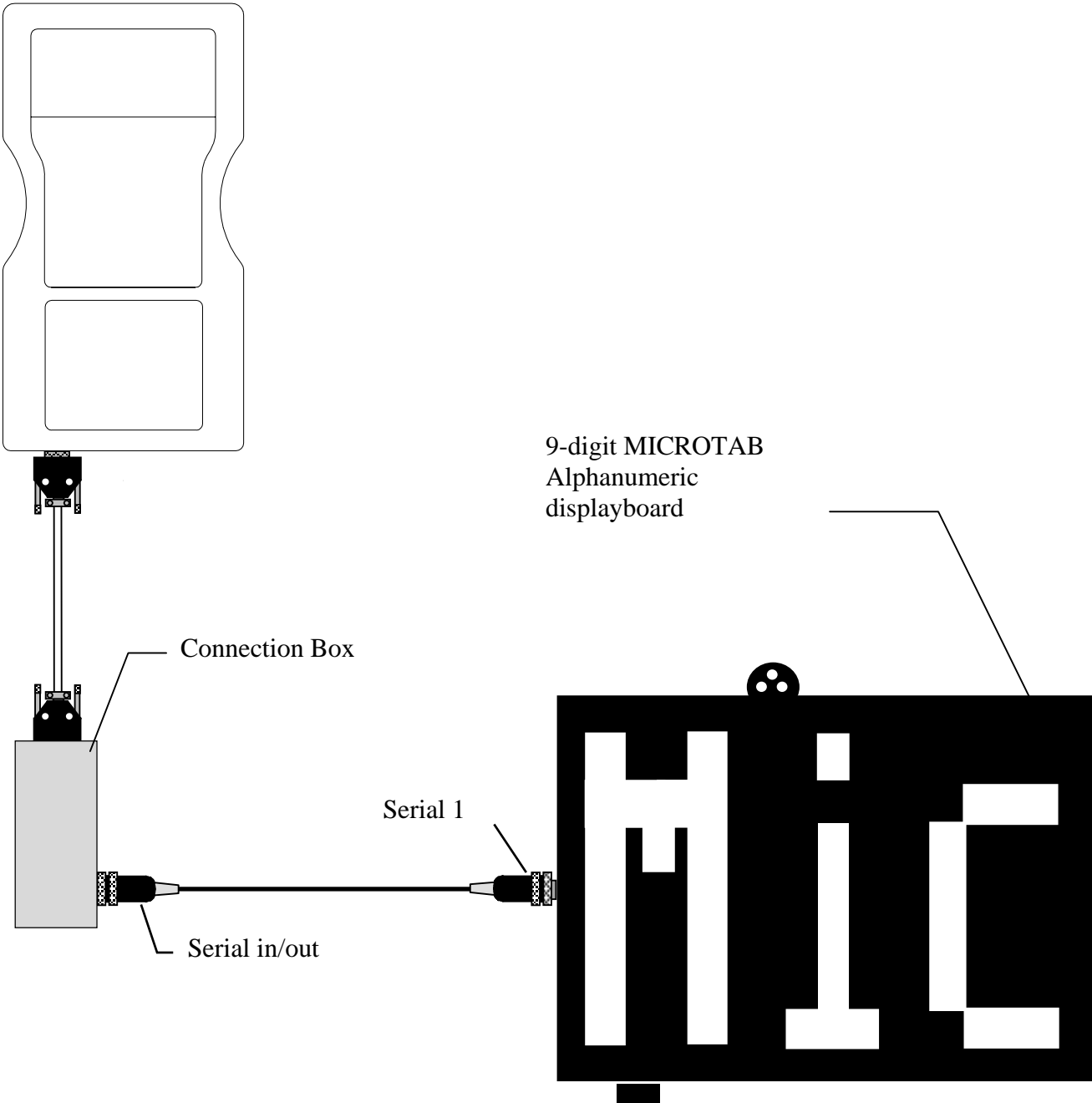

## 2.5 MEASURING SPEED

Fig. 23

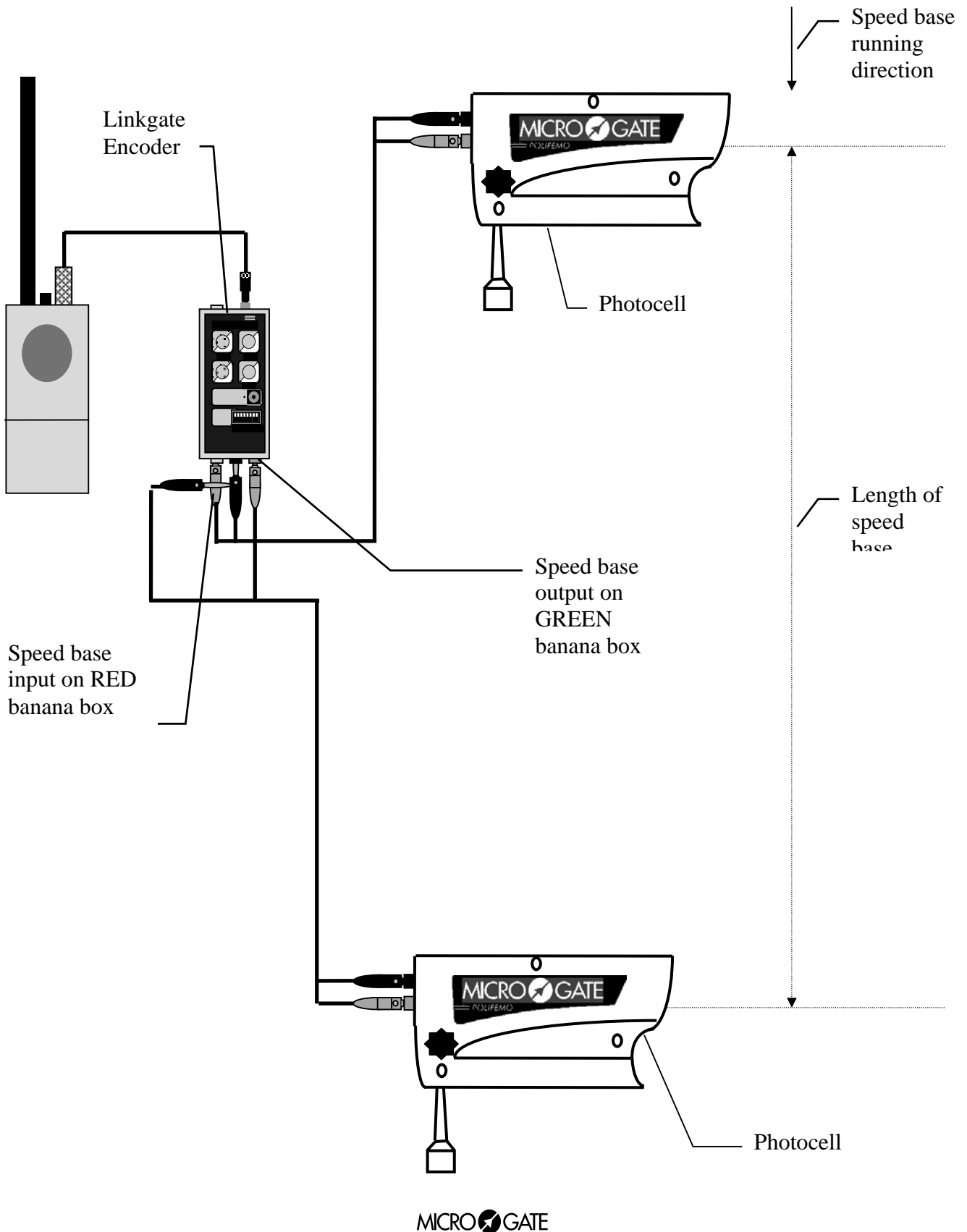

## 2.6 CONNECTING THE BATTERY CHARGER

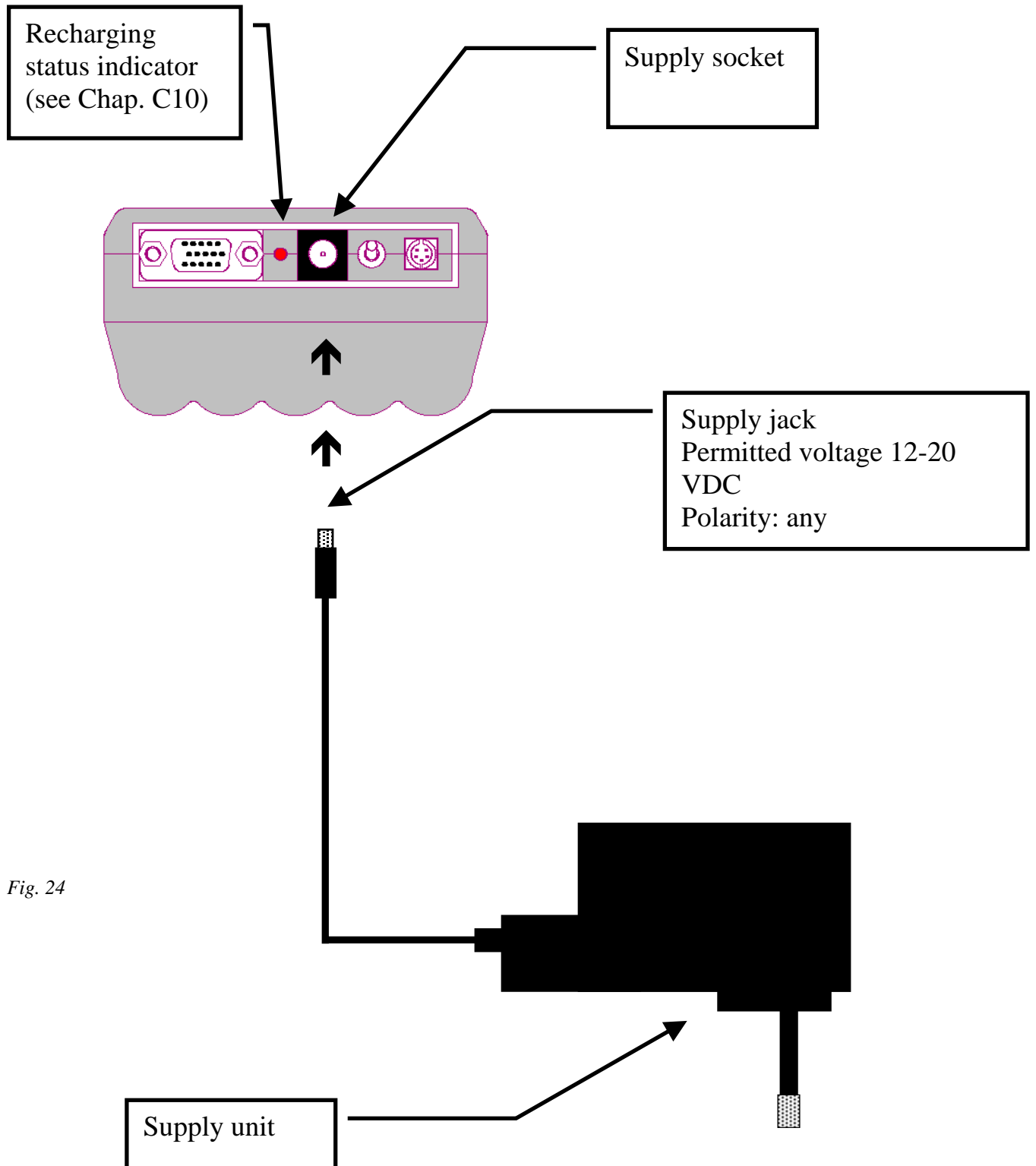
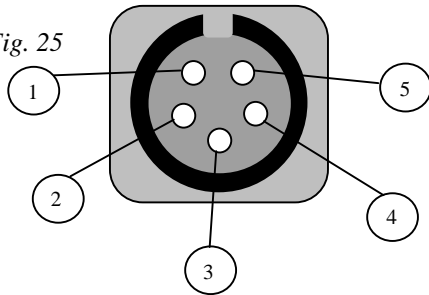

Fig. 24

## 2.7 CONNECTORS

**5 pole male panel connector**

Fig. 25



**3 pole female movable connector**

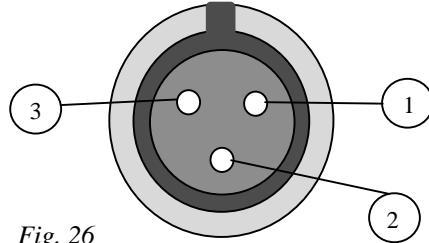
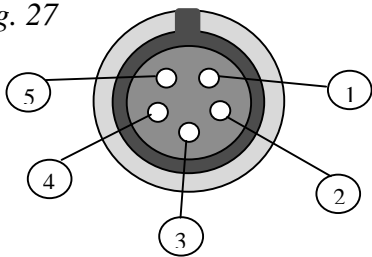

Fig. 26

**5 pole female movable**

Fig. 27



**15 pole male high density movable**

Fig. 28

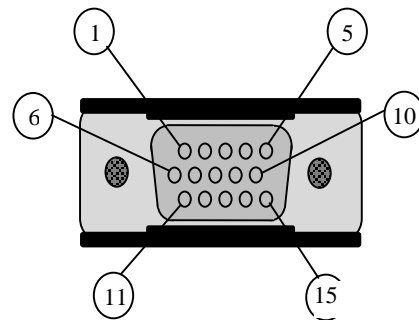

**6 pole male movable Amphenol plug**

Fig. 29

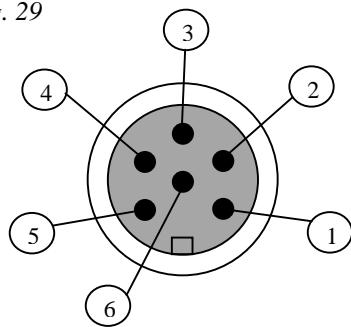

**9 pole male movable CANNON**

Fig. 30

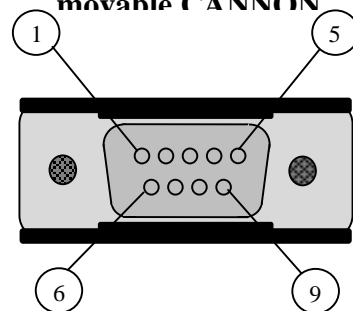

**5 pole male movable Amphenol plug**

Fig. 31

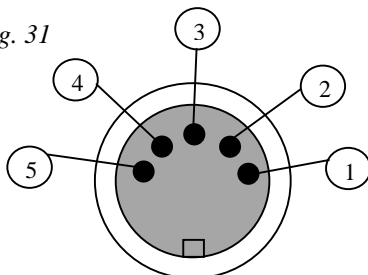



## 2.8 CONNECTION CABLES

**Note:** the numbering of poles refers to the numbers previously indicated.

Fig. 32

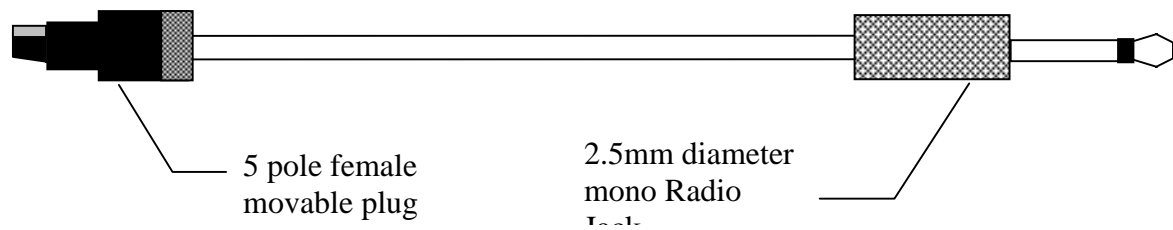

**5 pole female movable plug**

- 1.GND -----
- 2.Signal-----

**2.5mm diameter mono radio jack**

- Base= GND
- Point= Signal

Fig. 33

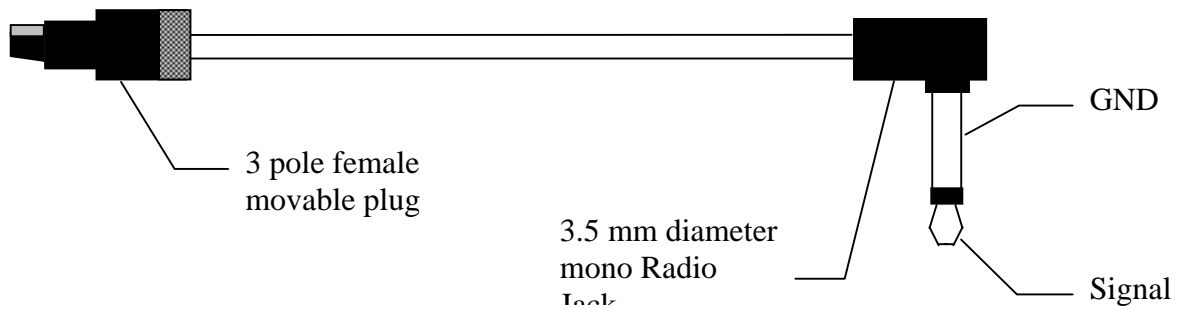

**3 pole Female movable plug**

- 1 Signal-----
- 3 Signal ground-----

**3.5mm diameter mono radio jack**

- Point= Signal
- Base= GND

**Linkgate Encoder – Racetime2 Cable (for serial download of data)**

Fig. 34

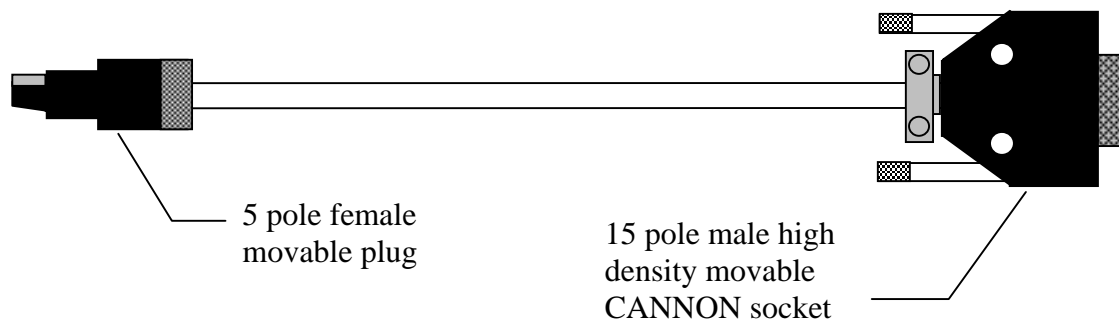

**5 pole female movable plug**

- 4. Photo coupler emitter-----
- 5. Serial photo coupler collector-----

**15 pole male high density movable CANNON socket**

- 15. Asynchronous serial, RX
- 2. +5 Vcc
- 12. Connected with 3900 Ohm resistance to pin 15

**Encoder – Photocell/Gate**

Fig. 35

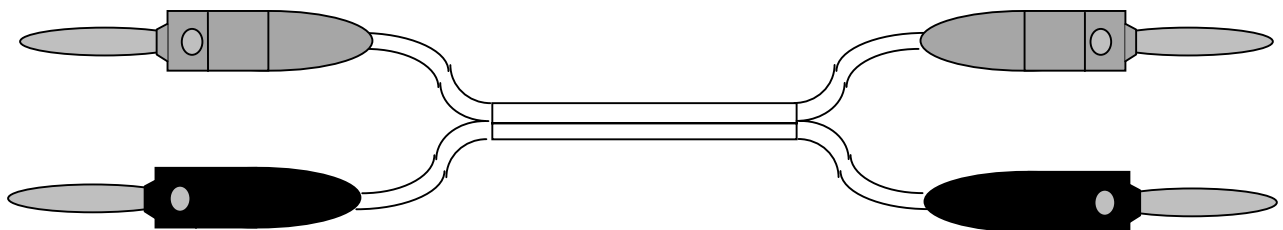

## Racetime2 – Connection Box Cable

Fig. 36

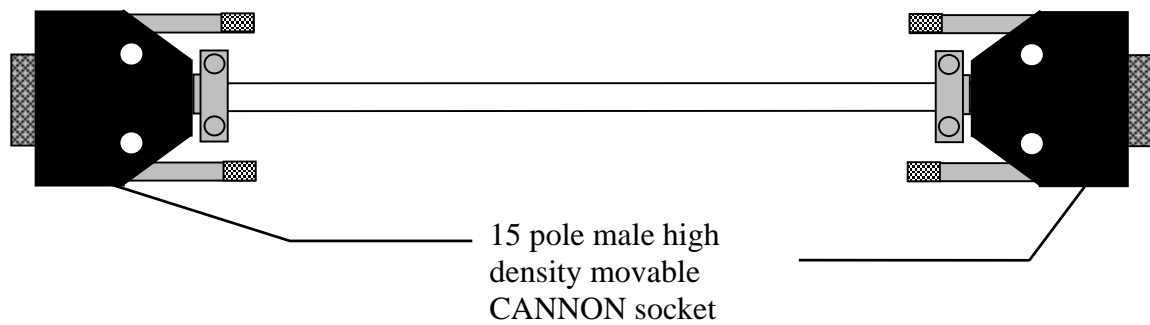

### 15 pole male high density movable CANNON socket

1. Digital ground
2. +5 Vcc out, max 500 mA
3. START signal
4. STOP signal
5. LAP signal
6. AUX signal
7. Analogic input 2
8. Analogic input 1
9. Analogic input 0
10. Analogic ground
11. Sync. serial, clock output
12. Sync. serial, TX
13. Sync. serial, RX
14. Async. serial, TX
15. Async. serial, RX

## Power Box - PC

Fig. 37

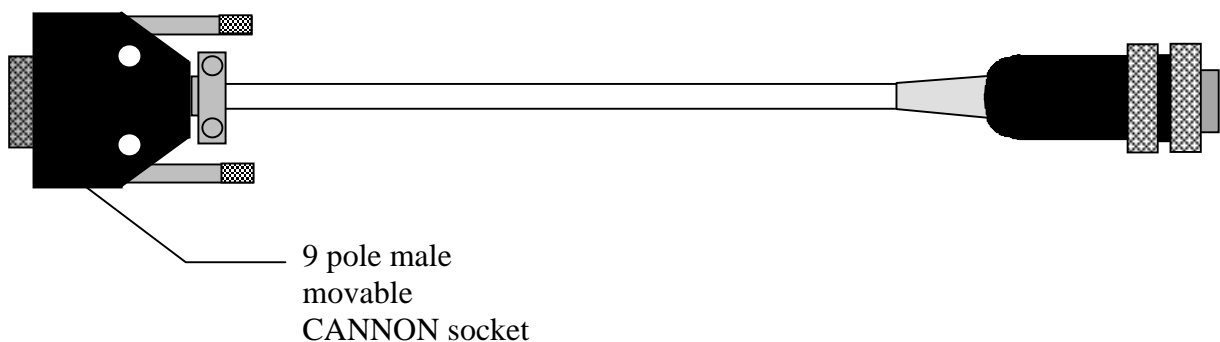

### 9 pole male movable CANNON socket

### 6 pole male movable Amphenol plug

- |                             |                        |
|-----------------------------|------------------------|
| 2. Serial input (RXD) ----- | 1. Serial output (TXD) |
| 3. Serial output (TXD)----- | 6. Serial input (RXD)  |
| 5. GND -----                | 5. GND                 |

1+4+6 connected to each other  
7+8 connected to each other

### Racetime2 – Photocell Cable

Fig. 38

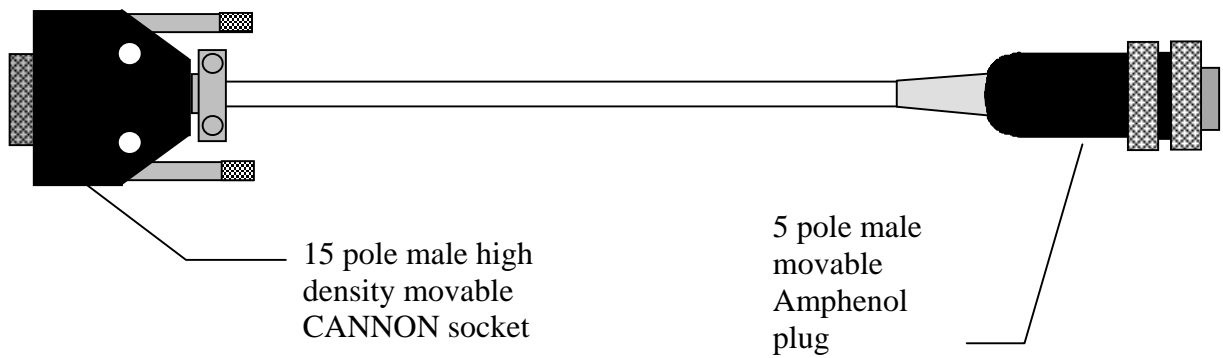

**15 pole male high density movable CANNON socket**

**5 pole male movable Amphenol plug**

1.Digital Ground-----	3.GND
2.+5 Vcc out, max 500 mA -----	2.+5V Vcc stabilized
4.Stop Signal-----	5.STOP

### Connection box – Displayboard Cable

Fig. 39

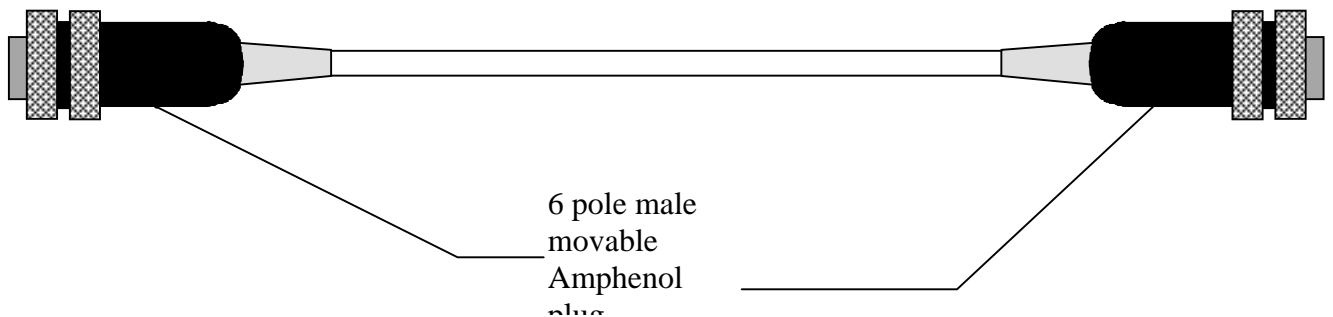

**6 pole male movable Amphenol plug**

1 .Serial Output (TXD)-----	6. Serial Input (RXD)
5. GND -----	5. GND
6. Serial Input (RXD)-----	1. Serial Output (TXD)



# **THE LINKGATE SYSTEM**

### 3 INTRODUCTION

The transmission of an impulse via radio is a critical phase in timekeeping. The possibility of losing the data transmitted, of having very inaccurate timing and the transmission difficulties in some zones has often made timekeepers and trainers skeptical about this type of approach.

The LINKGATE Encoder system represents a radical innovation in the field of radio transmission of impulses for timekeeping. Technological evolution has enabled us to go from the old impulse transmission systems to the more modern data transmission concept, which can guarantee extreme accuracy, the transmission of large quantities of information and greater reliability. In addition, the compact size of the system and the possibility of using it with any type of VHF or UHF transmitter radio makes the LINKGATE Encoder the ideal instrument for training and competitions at every level.

## 4 LINKGATE ENCODER : 3 features guaranteeing the reliability of radio transmission

To overcome unreliability and the various problems associated with the old system of radio transmission of impulses, LINKGATE Encoder offers a number of innovative solutions.

### 4.1 DIGITAL TRANSMISSION OF IMPULSES

Linkgate Encoder transmits sets of data (no longer a single impulse) that contain a vast amount of information. In particular, the following are transmitted:

- The transmitter's Code (which can be selected with the Channel Select switches)
- The Type of signal transmitted (Start, Lap number or Finish, which can be selected with the Signal Type switch)
- How long ago the event took place
- The running Time of a speed base (if present)

In addition, the kit contains numerous control codes and error auto-correction codes which prevent a signal from being incorrectly interpreted during reception.

All the data (information + control codes) is transmitted 16 times, in order to reduce the possibility of reception failure.

Even with very disturbed signal transmission, this system ensures maximum reliability and precision ( $\pm 0.4$  thousandths of a second); in short, you only need the complete reception of a single set of data to be able to reconstruct the original time of the event.

### 4.2 THE REPEAT FUNCTION

If there are any problems in data reception, (radio malfunction, interference from a more powerful transmission, a cable which comes unplugged, etc...) you can use the REPEAT function. Linkgate Encoder allows you to repeatedly re-transmit impulses which have not been received, even after a considerable length of time has passed.

As soon as the transmission of an event begins, Linkgate Encoder starts counting the time from the start. By pressing the REPEAT key, you transfer the correct time to the chronometer which takes into account the time which has passed up to that moment.

### 4.3 INTERNAL MEMORISATION OF EVENT TIMES

Linkgate Encoder is equipped with a Real Time Clock that allows you to use event times in event management. This special characteristic enables you to save the times of every event on a permanent memory. Then it gives you the possibility of downloading its contents through serial link onto Microgate's chronometers. The device memorizes the last 256 event times and speeds and therefore allows you to retrieve any data lost because of radio malfunction or any other reason.



## 5 USING YOUR LINKGATE ENCODER

### 5.1 SELECTING THE CHANNEL

Every Linkgate Encoder is equipped with a 7 switch panel (CHANNEL SELECT switch from 2 to 8 -- #7 fig. 6 page 11) for setting the transmission channel. The transmission channel is used in such a way that only the chronometers Racetime2 and REI set to the same channel for reception can recognize the transmission signal as valid. When it is turned on, every Microgate chronometer displays the currently selected channel (both as a number and as an ON/OFF configuration of the Linkgate Encoder switches). By choosing the same switch configuration on the Encoders that you want to use, you can be certain to receive only the signals from your own timing system. This type of filter for signals being received is particularly useful as, by selecting different channels you can use several systems (chronometer + Encoder) in the same zone and even on the same frequency without any risk of timings interfering with one another.

### 5.2 SELECTING THE TYPE OF SIGNAL

Linkgate Encoder can identify the type of impulse that is being transmitted (Start, Lap number or Finish). The rotary selector (marked SIGNAL TYPE - #5 fig. 6) has 16 positions from 0 to F with the following meanings:

0= START

1= LAP n° 1

.

A= LAP n° 10

B= LAP n° 11

C= LAP n° 12

D= LAP n° 13

E= LAP n° 14

F= STOP

The type of signal is chosen by placing the number or letter for the signal you want next to the black dot by the words SIGNAL TYPE. (Note: the letters are written on the edge of the selector).

### 5.3 IMPULSE TRANSMISSION

An impulse can be transmitted in two ways:

1) with the manual activation key (SIGNAL key - #1 fig. 6)

2) by means of any signal given by the closing of a contact normally open produced by a gate or photocell., using the BLACK banana jack as a ground (#2 fig. 7) and the GREEN banana jack as the signal (#3 fig. 7).

At the end of data transmission, the Linkgate Encoder will emit a BEEP, which signals that the device has functioned correctly.

By using switch #1 (next to the words SHORT IMPULSE LONG) you can set transmission duration (approximately 2.3 seconds for long transmission and 0.6 seconds for short). By choosing long transmission, you will obtain the greatest redundancy of information as the data will be transmitted 16 times. If you select short transmission the set of data will only be transmitted 4 times so you will have lower redundancy but with a substantial reduction of transmission time.

For normal use, we advise you to use long transmission (switch #1 OFF) in order to maximize the redundancy of transmitted data. However, for special applications such as the taking of several intermediate times very close together, using short transmission is the only practical solution if transmissions are not to overlap.

**IMPORTANT:** when using short transmission of impulses, it is advisable to turn the receiving radio's control to "SQUELCH" so that it remains constantly activated. In this way, you will avoid losing impulses as a result of the delay caused when the transceiver switches over to reception.

## 5.4 THE REPEAT FUNCTION

If for some reason data was not received by the Microgate chronometers you can retransmit to them by pressing the REPEAT key (#3. fig. 6) even after a considerable interval of time.

If the problem should continue, the event data can be re-transmitted as many times as necessary until satisfactory reception has been obtained.

## 5.5 CALCULATING A SPEED

With Linkgate Encoder you can receive up to 16 pass-by speeds from as many different measurement zones. The basic idea is to calculate the speed base time extremely accurately and transmit it together with the corresponding impulse (START, LAP or STOP). Then, by inserting the length of every single speed base into the Microgate chronometer, you can obtain the value for the average speed for that stretch.

The input speed base signal must be brought onto the RED banana jack (#1 fig. 7) and the relative ground onto the BLACK banana jack (#2 fig. 7); the output speed base signal must be brought onto the GREEN banana jack (#3 fig. 7) together with its ground which must be connected to the BLACK banana jack. When an impulse is received from a speed base input (from the RED banana jack), the LINKGATE Encoder sets the time running. If within 8 seconds there is an impulse from the speed base output (from the GREEN banana jack), the LINKGATE Encoder will transmit the time between the two signals (speed base time) and the impulse of the speed base output (that is, the corresponding LAP or STOP impulse). In the case of a START signal (with the rotating selector on position 0), the impulse of the output signal from the speed base will always be transmitted, but the receiving chronometer will reconstruct the correct time. If more than 8 seconds pass between an input speed base impulse and an output impulse, the system will automatically discard the value – only transmitting the output speed base impulse (the signal corresponding to the GREEN banana jack).

## 5.6 HARDWARE RESETTING

It is possible to reset Linkgate Encoder to hardware mode. The hardware reset deletes all the data in the memory, sets the internal clock to zero and, if the system has crashed for any reason, restores it to an operational state. On the back of the chronometer, there is a hole in the case. By inserting a pointed instrument you will press a button which will reset it. Keep the button pressed for a few moments to ensure the machine has been reset.

## 5.7 RESETTING THE MEMORY

Resetting the memory causes the deletion of stored data and of the system's internal time. You can activate reset by keeping the 2ND key pressed down and then releasing the REPEAT (RESET) key. When this command has been received, Linkgate Encoder will emit three tones as follows: BOOP-BEEP-BOOP. The system is reset!

## 5.8 SYNCHRONIZATION

Linkgate Encoder is equipped with a REAL TIME CLOCK which enables you to associate any event with a time. It is therefore possible to synchronize the Linkgate Coder's internal clock with any type of chronometer. The procedure for synchronizing the system is as follows:

- Connect the chronometer's ground (GND) with the Linkgate Encoder's BLACK banana jack
- Hold down the 2ND key and then press and release the SIGNAL (SYNC) key
- Linkgate Encoder will emit the tones BOOP-BEEP (the system is waiting for a START)
- Connect the start line to the GREEN banana jack
- Within two minutes give a start signal to synchronize the system (either by pressing the SIGNAL key or by closing the start line on the ground)
- On receiving a START signal, Linkgate Encoder will emit two tones: BEEP-BOOP (the system is synchronized)

If you wish to synchronize two or more Encoders with a chronometer, the procedure remains the same. You must connect all the ground lines (BLACK banana jack) with the chronometer's ground; then for every Linkgate Encoder you must activate the SYNC procedure (the second point in the procedure), connect the starting line to all the GREEN banana jacks and give a common START.

**NOTE:** Linkgate Encoder automatically synchronizes itself to the time 00:00:00.000; it is not possible to set other times.

## 5.9 DOWNLOADING DATA ONTO RACETIME2

Linkgate Encoder memorizes the last 256 events and the last 256 speeds (if received) on an internal permanent memory and so makes possible retrieval after an interval of time of any impulses 'lost' as a result of radio malfunction or for any other reason. To be able to download the contents of the Linkgate Encoder's memory onto the Racetime2 Chronometer, it is necessary to use the appropriate cable (fig. 34), which should be connected to the 5 pole connector (fig. 25) of the LINKGATE Encoder at one end, and at the other to the 15 pole connector (fig. 28) of Racetime2 (fig. 25). Once the correct menu has been selected on Racetime2's chronometer (chap. C11.3), you can proceed with data downloading by pressing the 2ND key and then by pressing and releasing the 'MODEM' (SERIAL) key. The start of downloading is signalled by the two tones BOOP-BEEP; then within 2 seconds two counters will appear on Racetime2's display screen to indicate the number of times and speeds actually downloaded. At the end of data downloading, the two tones BEEP-BOOP indicate that the procedure has terminated correctly.

**ATTENTION:** if you download data immediately after performing a memory RESET (2ND + REPEAT (RESET)) and without transmitting any impulses, LINKGATE Encoder will download the entire contents of the memory (256 times + 256 speeds).

**IMPORTANT:** During data downloading onto Racetime2, disconnect the Linkgate Decoder from the chronometer. Also disconnect the data download cable during timing via radio.

## 5.10 THE MODEM FUNCTION

Linkgate Encoder can also be used as a modem transmitter. Contrary to what happens when transmission is generated during an event, however, input does not take the form of sets of data with error correction codes, but is simply transformed into a signal compatible for radio transmission. Data reliability is left entirely to the effectiveness of the radio system.

In this function mode, Linkgate Encoder accepts a Serial signal for inputs with a maximum speed of 1200 Baud and generates a FSK modulation between 1200 Hz (logic signal 0) and 1800 Hz (logic signal 1).

The digital input signal (level RS 232, RS 485 or TTL) is connected to the blue banana jack (#5 fig. 7 - signal) and the black banana jack (#2 fig. 7 - reference).

The MODEM function can be activated by pressing the 'MODEM' key 3 times consecutively and rhythmically. At the first two presses, you will hear a BEEP tone. At the third, the tones BOOP-BEEP will signal entrance into MODEM function. If the key is not pressed with the correct rhythm, the system will refuse to enter this mode. The reason for this complicated procedure for activating this function is that the MODEM function quickly uses up the battery. In this way you can avoid the danger of rapidly running down the battery by accidentally touching the MODEM key.

To terminate the transmission session you need only press the MODEM key once. The system will emit the tones BEEP-BOOP to signal correct termination procedure.

## 5.11 MAINTENANCE

The system is designed to avoid the need for any type of standard maintenance. In normal working conditions the lithium battery (3.6 V) has a life of approximately 6 years. When the Linkgate Encoder is in a situation of limited autonomy, it emits an acoustic signal to warn the user. The low battery signal consists of three brief tones: BEEP-BEEP-BEEP, at the end of an impulse transmission. In this case, you should immediately contact your MICROGATE representative or the company for battery replacement and an overhaul of the system.

NOTES

Lined area for notes, consisting of 25 horizontal lines.

# **PROGRAMS**

## 6 Instructions for reading the manual

Reading the manual is made easy and intuitive by the numerous illustrations which explain step by step what appears on the display and which keys to press. Here is an example of what you will find in it.

Clear all  
Stored data?  
Yes No

1 2 4 3

A:Single start  
B:Group start  
C:Simple stopwatch  
A B C more

5 6 8 7  
*1.1 1.2 1.3*

P 0002 12.14.54  
A 0001 00.53:123  
Ins. num: 0

9 10 12 11

You are always shown what appears on the display at that moment

Pressing **F4** will take you back to a point previously explained

Pressing **F3** will move you on to the next screen

**Chapter reference:** to have further details about a point you can access with **F3** (in this case 'Rankings Printout') go to chapter 1.3 (the number and name of the chapter and paragraph are always shown at the top right-hand side)

A time written in *Italics* means that this time is running on the chronometer

An underlined digit shows that the blinking **cursor** is in that position and the chronometer is waiting for **input**

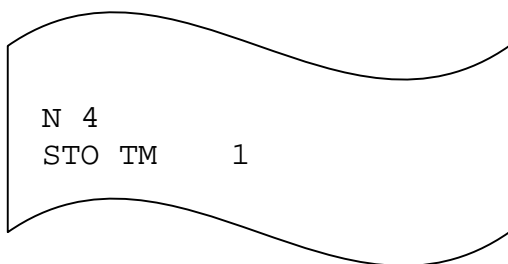

Example of a **printout**: you are shown what would be printed by the printer at that point

## 7 General information

The software of Microgate's Racetime 2 Chronometer consists of various programs for different modes of functioning which make it possible to use the device for most sports, both during training and in official competitions.

Depending on the software version in your possession, it is possible that some of the functions described in this manual cannot be used with your system. At the beginning of each chapter, the program versions which can be used for the function to be described are clearly indicated.

When you switch on Racetime2, the software version installed will be shown on the display. The following screen will appear:

```

Microgate - Italy
RACETIME 2 - Vx.y.zz
SN #####
CH. ### (s#####)
    
```

From the code of the software version installed (Vx.y.zz), it is possible to immediately determine the program options with which your chronometer is equipped.

Version	Single Start + Simple Stopwatch	Test material	Group Start	Parallel	PC On-Line	Show Jumping	Not Microgate Boards control	Optojump
1.x.vv.	✓							
2.x.vv	✓	✓						
3.x.vv	✓		✓					
4.x.vv.	✓			✓	✓			
5.x.vv	✓		✓	✓				
6.x.vv	✓	✓	✓					
7.x.vv	✓	✓	✓					
8.x.vv	✓	✓	✓	✓	✓			
9.x.vv	✓	✓		✓				
10.x.vv								✓
11.x.vv	✓							✓
12.x.vv	✓	✓						✓
13.x.vv	✓		✓					✓
14.x.vv	✓				✓			✓
15.x.vv	✓		✓	✓				✓
16.x.vv	✓	✓	✓					✓
17.x.vv	✓	✓	✓					✓
18.x.vv	✓	✓	✓	✓	✓			✓
19.x.vv	✓	✓		✓				✓
20.x.vv	✓	✓	✓	✓	✓		✓	
21.x.vv.	✓	✓	✓	✓	✓		✓	✓
22.x.vv	✓						✓	
23.x.vv	✓	✓			✓			
24.x.vv	✓	✓	✓	✓	✓	✓	✓	

The two numbers after (y.zz) indicate your software version.

After that, you will see indicated the serial number of your Racetime2 and the channel currently set for reception of signals via radio (see par. C.10.1.9 and chapter B - Microgate LINKGATE's radio system for further information on the subject).

**Note:** if you contact Microgate for any problems or explanations, please be sure to indicate the serial number and the software version of your Racetime2.



## 7.1 FUNCTION AND CE KEY USE

The four function keys (**F1**, **F2**, **F3** and **F4**) enable the user to ‘converse’ with the machine. All the operational choices are shown on the bottom line of the display (menu line). To select the option you want, just press the corresponding function key. If an arrow appears at the beginning or end of the menu line, this means that a second group of setting options is available. You can go to them with CE.

If you hold down the CE key for more than 0.6 seconds, the printer paper will move forward (provided your printer is connected - see par. 10.1.11).

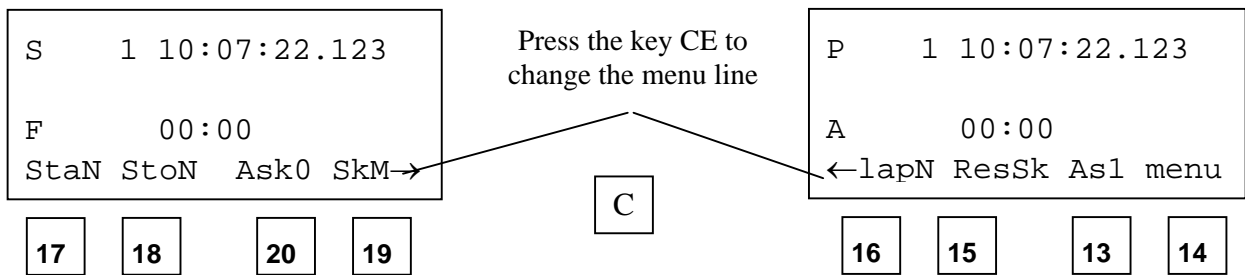

## 7.2 NUMERICAL DATA INPUT

It will often be necessary to insert numerical data (for example, an athlete’s start number) with the numeric keyboard. This possibility is indicated by a blinking cursor on the relevant field.

After indicating the number you want, you can confirm it by pressing **ENT** (Enter). If any options are available on the menu line, you can quit the input data phase by pressing one of the active function keys. In this case the number inserted will be used as input data for the operation you have chosen, as will be clear in chapter C.3 (‘Timing’).

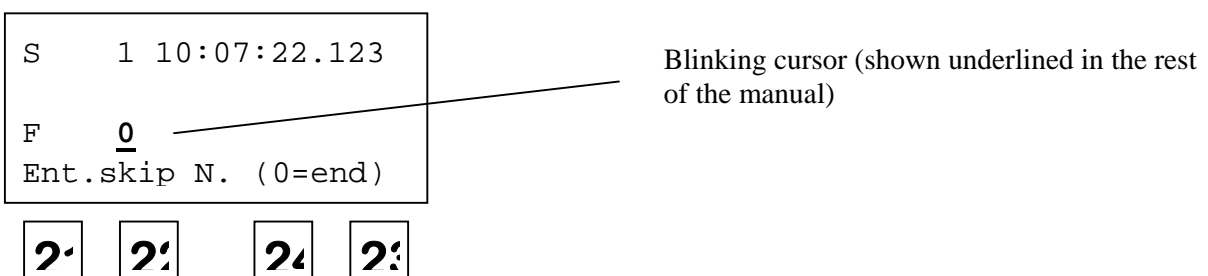

```

Microgate - Italy
RACETIME 2 - Vx.y.zz
SN #####
CH. ### (s#####)
    
```

29 30 32 31

```

Memory corrupted
Press ENTER
    
```

25 26 28 27

```

System halted
Call MICROGATE
    
```

33 34 36 35

```

Clear all
Stored data?

          Si  No
    
```

37 38 40 39

```

A:Single start
B:Group start
C:Simple stopwatch
A   B   C more
    
```

41 42 44 43

```

A:Parallel mode
B:PC ON-LINE mode
C:OptoJump
A   B   C menu
    
```

45 46 48 47

### 7.3 SWITCHING ON THE MACHINE

After switching on the machine, you will see the screen display previously described. Press a key to proceed. At this point one of the following screens will appear:

This message appears if the device completely emptied itself after the last work session. Any data previously stored has been irretrievably lost. Press ENTER to continue.

This message appears if something has gone wrong during the initial tests on the machine. Contact Microgate for further information.

This message normally appears when you switch on. Press **F3** to cancel the timing data previously stored (you must confirm your choice).

It is possible to choose the function mode only if stored data has been erased.

The following screen will appear.

By pressing **F4** (other) you can access other function modes.

Press **F4** (menu) to return to the previous screen. With the function keys, select the required function mode (the following chapters provide a detailed description of the various operational modes).



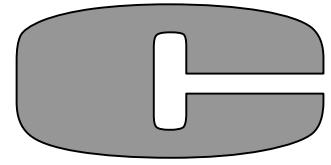

# **SINGLE START AND GROUP START PROGRAM**

## 8 Single Start and Group Start Modes

These two function modes will allow you to time very easily the great majority of sporting events, from alpine skiing to cross-country skiing, from various types of 'in line' start competitions to those races with 'mass' starts.

The difference between the 'single' and 'group' start forms is the way in which the numbers which appear on the Racetime2 starting line are considered.

In the first case (Single starts) both start and finish numbers refer to the single athlete (or single team). Consequently, for each start there will be one finish. In group starts, on the other hand, the start numbers refer to a group of competitors who will have to start at the same time. However, the finish numbers will refer to single athletes and net times will be calculated according to the group the athletes belong to.

When you have chosen a function mode, the following screen will appear:

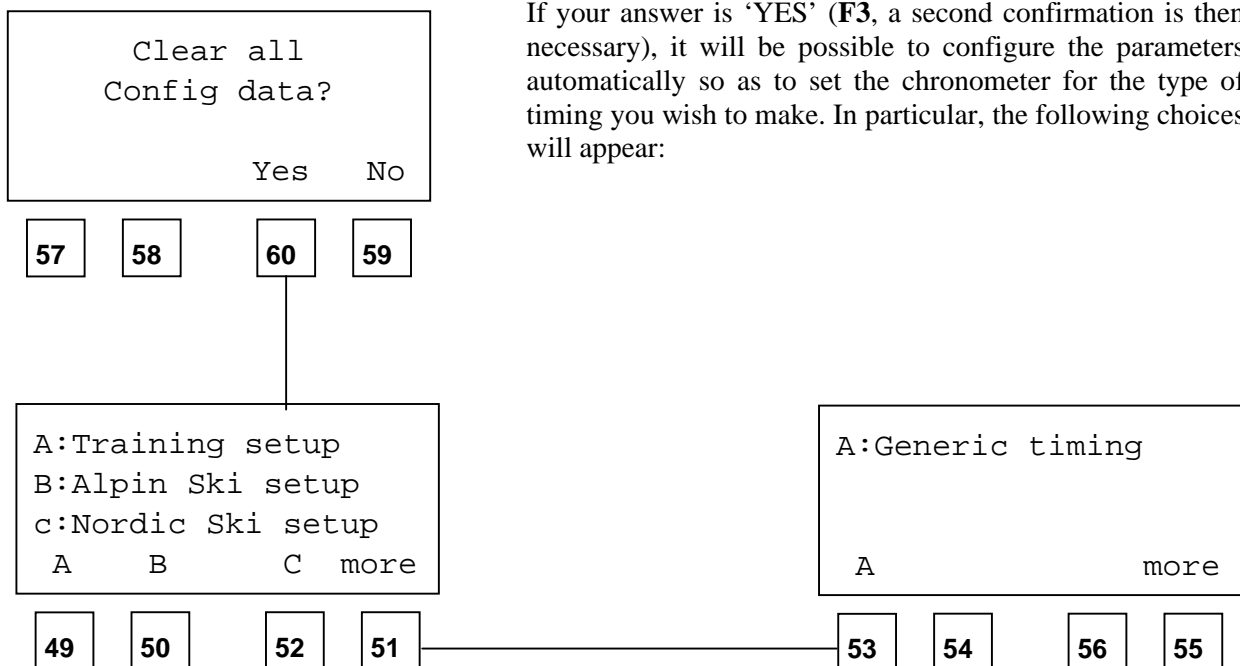

If your answer is 'YES' (F3, a second confirmation is then necessary), it will be possible to configure the parameters automatically so as to set the chronometer for the type of timing you wish to make. In particular, the following choices will appear:

The following configuration parameter settings correspond to each of the various options (for a complete description of the meaning of each parameter, see chap. C.10):

### Training Configuration

Automatic finish search: enabled

Automatic assigning of net times: activated

Maximum time: 3 minutes

Display of net times: single run times

Printout of event times: deactivated

Net time print mode: print after finish

Measurement accuracy: 1/100s

Input deactivation time ('dead times'): Start 2s, Lap 0.5s, Stop 0.5s

Unit of speed measurement: km/hr

**Alpine Skiing Configuration**

Automatic finish search: enabled

Automatic assigning of net times: deactivated

Maximum time: 3 minutes

Display of net times : total times

Printout of event times: deactivated

Net time print mode: print after finish

Measurement accuracy: 1/100s

Input disactivation time ('dead times'): Start 2s, Lap 0.5s, Stop 0.5s

Unit of speed measurement: km/hr

**Cross-Country Skiing Configuration**

Automatic finish search: disabled

Automatic assigning of net times: deactivated

Maximum time: unlimited

Display of net times: single run times

Printout of event times: deactivated

Net time print mode: print after every event

Measurement accuracy: 1/10s

Input disactivation time ('dead times'): Start 2s, Lap 0.5s, Stop 0.5s

Unit of speed measurement: km/hr

**Generic Timing Configuration**

Automatic finish search: disabled

Automatic assigning of net times: deactivated

Maximum time: unlimited

Display of net times : single run times

Printout of event times: deactivated

Net time print mode: print after every event

Measurement accuracy: 1/100s

Input disactivation time ('dead times'): Start 2s, Lap 0.5s, Stop 0.5s

Unit of speed measurement: km/hr

## 9 Main Menus

A:Timing program  
 B:Ent./print groups  
 C:Printouts/Rankings  
 A B C more

61 62 64 63  
 3 4 5

A:Autom.start  
 B:Dispualif.  
 C:Synchronize  
 A B C more

65 66 68 67  
 6 7 8

A:Send stored data  
 B:LINKGATE download  
 C:Signal level  
 A B C more

69 70 72 71  
 9 11.3 11.4

A:RACETIME config.  
 B:Disp.Board conf.  
 C:Skitest config.  
 A B C more

73 74 76 75  
 10.1 10.3 10.2

A:Time calculator  
 B:Battery charge  
 A B menu

77 78 80 79  
 11.5 11.1

Select the items with the four function keys:

- A. To enter timing mode
- B. To enter the group management and printout submenu
- C. To enter rankings
- F4. To show next menu

Select the items with the four function keys:

- A. Automatic start management
- B. Disqualifications management
- C. To synchronize the internal clock
- F4. To show next menu

Select the items with the four function keys:

- A. Data transmission to PC
- B. To receive data from LINKGATE module
- C. Radio signal quality test (Linkgate system)
- F4. To show next menu

Select the items with the four function keys:

- A. Machine configuration
- B. To access displayboard configuration menu
- C. To access skitest configuration menu
- F4. To show next menu

Select the items with the four function keys:

- A. To access time calculation function
- B. To access battery charge function
- F4. To main menu

## 10Timing

```

A:Timing program
B:Ent./print groups
C:Printouts/Rankings
  A      B      C  more

```

85 86 88 87

Wich run? \_\_\_\_\_

81 82 84 83

```

S      1  10:07:22.123
F
StaN StoN Ask0 SkM→

```

89 90 92 91

Press **F1** for timing; to get to know the machine, practice with the manual keys START-STOP-LAP, which will then be replaced by starting gates and photocells.

Set the run number (usually the last number used is shown), which will immediately be printed.

During timing, the display lines show the following information:

**Line 1:** This is for the start and shows the number of the athlete starting and the current time (which can be set by selecting 'Synchronization' from the main menu - see chap.C8).

**Line 2:** Normally empty, it is used to set the lap number, to display speeds transmitted from the Microgate LINKGATE system and to show the number of events (starts, laps and finishes) in the events memory (maximum 64 times).

**Line 3:** It is used to show net times either for finish or laps and to insert the start numbers of athletes at the finish or for laps.

**Line 4:** Normally offers a menu of operational choices which can be activated with the function keys; sometimes messages for the user are displayed.

The start number automatically increases after each start.

If the 'automatic finish search' is activated, (see par. C10.1.3), at the finishing line the number of the first athlete to start from among the numbers of athletes still in the race will be shown. However, it is possible to use the keys  $\uparrow$ - $\downarrow$  to run through the athletes still in the race or to set directly the number of the athlete who is finishing.

As you will be able to see from the following notes, Racetime2's software is extremely flexible and makes possible all types of modifications and/or corrections. It is important to note that every operation can be made with the necessary calm as all the events which take place while you are making a correction or modification are automatically memorized in a 'buffer memory' which is capable of holding 64 events. These are then presented to the user in the same sequence in which they took place.



## 10.1 INSERTION/CORRECTION FUNCTION

### 10.1.1 Start number insertion/correction

Select Nsta (Start Number) with the F1 key. Use the numeric keyboard to set the number. (Once again it must be remembered that if group function mode has been set, this number refers to the group and not to the single athlete). Then with ENTER confirm the number, which will be the next number to start. If this number has already started, the anomaly will be signalled and it will be possible to cancel the previous start.

You can also confirm the setting by pressing one of the function keys F1, F2, F3 or F4 (Cle Repl Evt NS) instead of ENTER. In this case you will obtain the following results:

S	_	10:07:22.123	
F			
Cle	Repl	Evt	NS
93	94	96	95

**F1 (Cle - Clear):** cancels the start time set - however, you are asked to confirm before cancellation takes place

**F2 (Repl- Replace):** assigns the event time for the number set to another number which must be subsequently inserted in the fourth line

If the number to which the event time is to be assigned (the second number set) has already been used you can choose whether to cancel the previous event time (Cle - F2 key), switch the two event times around (Repl -F3 key) or leave the stored data unchanged (Esca - F4).

**F3 (Evt – Edit event time):** makes it possible to modify the start time of the set number. This option also enables you to insert starts ‘manually’. All you need to do is simulate the athlete’s start by activating the start key on the keyboard and then change the time

**F4 (NS – Non starters):** inserts the number assigned in the list of non-starters and prints the event time with the code ‘NS’. The ‘non-starters’ can then be printed (par. C5.4). However, it is possible to ‘restart’ an athlete previously marked ‘NS’ simply by calling him up again and canceling the previous operation.

```

P      1 10:07:22.123
A              00:00
StaN StoN Ask0 SkM→

```

```

97  98  100  99

```

```

S      2 10:07:22.123
F      _ 10:04:12.123
Cle Repl Eevt NS

```

```

101 102 104 103

```

### 10.1.2 Finish number insertion/correction

Select StoN (Stop Number) with the key F2. Use the numeric keyboard to set the number. The number always refers to the start number of the single athlete even if you are working in 'Group start' mode. Then with ENTER confirm the number, which will be the next number to finish or to pass an intermediate time point. If this number (or the group which it is in) has already started, the net running time will appear on the screen display and displayboard. If the number has not yet started, running time will be shown only after the start.

You can also confirm the setting by pressing one of the function keys F1, F2, F3 or F4 (Cle Repl Eevt NS) instead of ENTER. In this case you will obtain the following results:

**F1 (Cle - Clear):** cancels the set finish time - however, you are asked to confirm before cancelation takes place

**F2 (Repl - Replace):** assigns the event time for the number set to another number which must be subsequently inserted in the fourth line. It also calculates the net times of the new number to which the event time is assigned. If the number to which the event time is to be assigned (the second number set) has already been used you can choose whether to cancel the previous event time (Cle - F2 key), switch the two event times around (Repl - F3 key) or leave the stored data unchanged (Esca - F4).

**F3 (Eevt - Edit event time):** makes it possible to modify the finish time of the set number.

**F4 (NS - Non finishers):** inserts the number assigned in the list of non-finishers and prints the event time with the code 'NS'; at the same time the number is removed from the list of athletes in the race. The 'non-finishers' can then be printed (par. C5.4). However, it is possible to reinstate an athlete previously marked 'NS' simply by calling him up again and canceling the previous operation.

### 10.1.3 Use of keys ↑ ↓

On the display the ↑ and ↓ keys allow you to run through the athletes on the track at that moment. Press ↑ to view the athlete who started before the one currently shown on the display; press ↓ to view the athlete who started after.

### 10.1.4 Turning the Autoskip function on and off

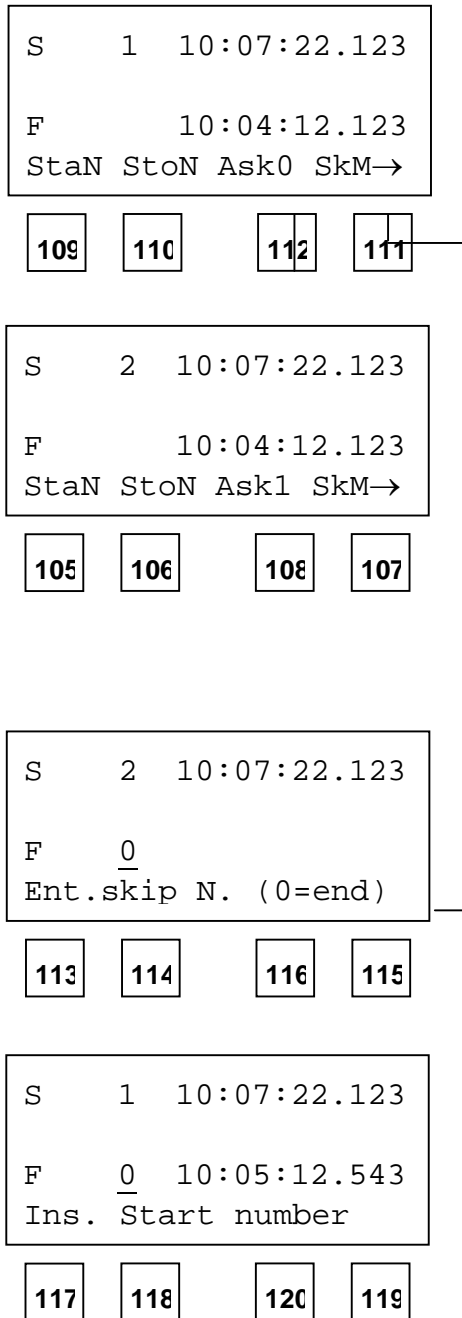

The Automatic Skip function (that is, the automatic assignment of a consecutive number to all lap or finish timings and temporary memorisation for later assignment to a start number) can be turned on or off using the F3 (ASk0/ASk1) key. On the display the current status of the function is indicated: Ask0 means that the function is OFF and Ask1 means that it is on. See also paragraphs C1.4, C1.6 and C3.3 for further information about the Skip function.

**Note:** You cannot use the Autoskip function if the printer is not connected

### 10.1.5 Skipped management (SkM)

This enables you to assign numbers after an interval of time to events previously 'skipped' with the 'skip' function. To access this function, press **F4** (Gsk) from the timing menu.

Insert the skip identification number and then the start number to which it must be assigned.

If such an event has already been assigned to the start number indicated (e.g. two finishes for the same start number), the anomaly is signalled and you can cancel the previous event.

To assign the same 'skipped' event to more than one number, you need only to recall the relevant skipped number and repeat the procedure. In this case, the message 'Already assigned' will appear on the display.

### 10.1.6 Editing or displaying intermediate times

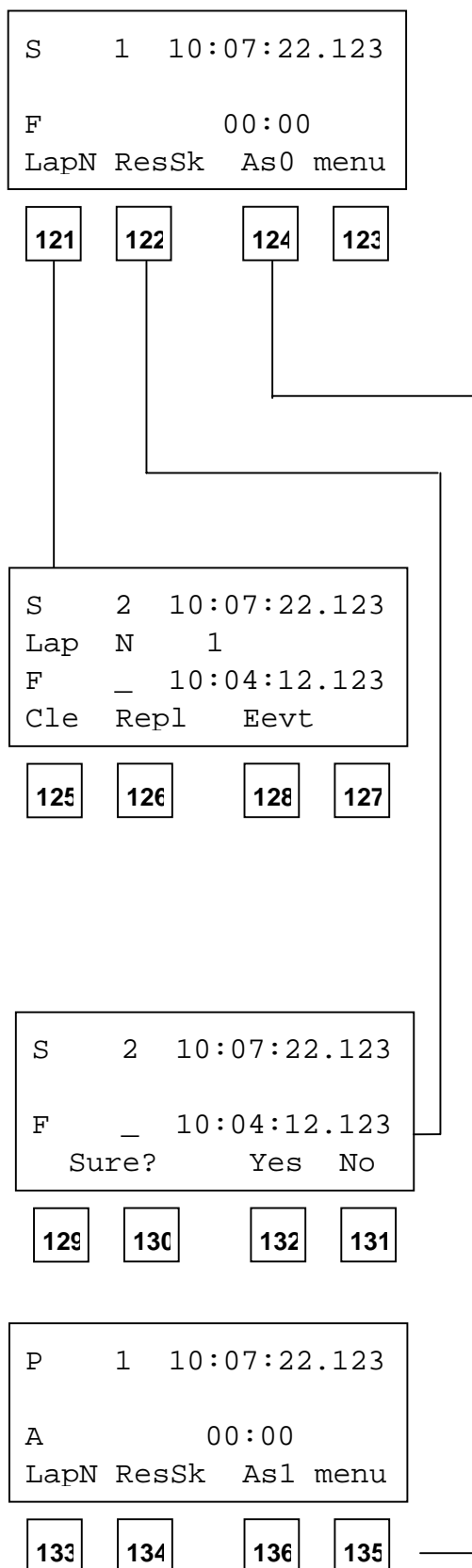

Choose LapN (Lap Number) by pressing F1 from the SECOND screen display of the timing menu. (Remember that to access the second screen display you must press the key CE - see also par. C.2.1). Set the intermediate time number on the second line and then the start number on the third line. This number always refers to the start number of the single racer, even if the 'Group Start' mode has been set. Now with ENTER, the intermediate time for the selected start number and intermediate stage number will be displayed. You can return to the previous screen by pressing the ENTER key a second time. This operation has no effect on stored data.

Instead of using the ENTER key, it is also possible to confirm the setting by pressing one of the function keys **F1**, **F2** or **F3** (Cle Repl Eevt). In this case, you will obtain the following results:

**F1 (Cle - Clear):** cancels the set finish time - however, you are asked to confirm before cancelation takes place.

**F2 (Repl- Replace):** assigns the event time for the number set to another number and/or another intermediate time number. The start and intermediate time numbers to which the event time is to be assigned should then be inserted following the instructions in the fourth line of the display. This function also calculates the net times of the new number to which the event time is assigned. If the number to which the event time is to be assigned (the second number set) has already been used you can choose whether to cancel the previous event time (Cle - F2 key), switch the two event times around (Repl -F3 key) or leave the stored data unchanged (Esca - F4). **F3 (Eevt - Edit event time):** makes it possible to modify the intermediate time of the set number.

### 10.1.7 Cancelling Skipped events memory.

Skipped events which have not yet been assigned can be canceled in a block by pressing the F2 key from the SECOND screen of the timing menu. Cancellation is irreversible and must therefore be confirmed before it is carried out.

### 10.1.8 Activation/disactivation of automatic assignment of finishes and intermediate times on and off

When the function for automatic assignment of finishes and intermediate times is on, the net time calculated when there is an intermediate time or finish is automatically assigned to the athlete and memorised 5 seconds after the timing is taken. This only takes place if the racer was already 'on line' (that is, if the net time was running) before the event. Even if no athletes were 'on line', manual assignment and confirmation are still necessary.

The current status of the automatic assignment function is indicated by the symbols ‘AS1’ (on) and ‘AS0’ (off). Key F3 ( on the SECOND screen of the timing menu) enables you to turn the function on and off.

```

S      1  10:07:22.123
F
LapN ResSk  As0 menu
    
```

137    138    140    139

```

          Clear all
          Config data?
          Si      No
    
```

141    142    144    143

### 10.1.9 Returning to the main menu

To return to the main menu, press CE to go to the second line of the menu and then press F4.

### 10.1.10 Returning to the main menu during timing

It is possible to return to the main menu and so reconfigure the device, make printouts or prepare rankings even when one or two athletes are on the track. Any Start-Stop-Lap signals that arrive while RACETIME is not set to the timing function and while some athletes are still on the track, are memorised. In this case, when you return to the timing function, the following display appears:

Select **Yes (F3)** if you do not wish to process the events and **No (F4)** if you do.

## 10.2 MANAGEMENT OF EVENTS

### 10.2.1 Displaying starts

```
S      3* 10:07:22.123
F              00:00
StaN StoN Ask0 SkM→
```

145 146 148 147

```
P      1 10:07:22.123
A              00:00
Cle                      NS
```

149 150 152 151

When a start takes place (single or group), the time of day shown on the first line of the chronometer stops for 5 seconds, indicating the starting time. At the same time, an asterisk blinks between the number of the starting competitor/group and the time. If 'print event times' and the printer are activated, the time is printed out. During these 5 seconds, it is not possible to correct the starting number

In particular, by setting a number different from the one presented and confirming with ENTER the start is assigned to the number set.

Simply by pressing ENTER (without changing the competitor number) the start of the number presented is confirmed.

It is also possible to annul the event with F1 (Ann) (if the START impulse was accidental) or declare the competitor to be a Non Starter by pressing F4 (NP). When the competitor is declared NP, the start time is automatically assigned to the next competitor due to start.

The start event can in any case be corrected later (see the paragraph on this subject).

If automatic assignment of finishes is disabled and there are a number of events that have accumulated in the memory, Racetime 2 automatically enters the correction mode described above when the START events must be managed.

```
S      1  10:07:22.123
F
StaN StoN Ask0 SkM→
```

153 154 156 155

STO

```
S      2  10:07:22.123
F      12      34.567
Cle. Skip Eevt S.T.
```

157 158 160 159

fig. A

```
P      2  10:07:22.123
A      0  10:06:21.547
Cle. Skip Eevt S.T
```

161 162 164 163

fig. B

### 10.2.2 Finishes management

If a finish number has been set (with the chronometer showing net running time on line 3), when a stop signal arrives (whether manual, from input or via radio) the net time in relation to the number previously set is shown (fig. A).

However, if no number has been set (stop line on 00.00 or with the finish or intermediate time of the previous number, or net time for a group still running - this last case being identifiable by the presence of the letter 'G' on the third line on the left of the display), the event time for the finish will be shown (fig.B).

In both cases you are asked to insert a start number. The time of the number indicated or previously displayed can be confirmed by pressing ENTER. Important: the assignment of the time to the number displayed takes place automatically if the function for automatic assignment of net times is on (see par. C3.1.8). If the number has already finished, this is signalled and it is then possible to cancel the previous finish.

You can also confirm the setting by pressing one of the function keys F1, F2, F3 or F4 (Cle Repl Eevt NS) instead of ENTER. In this case you will obtain the following results:

**F1 (Cle – Clear):** cancels the event. This is the option to choose if the stop impulse was accidental (e.g. unintentional crossing of the finishing line) – however confirmation is requested before cancelation takes place.

**F2 (Skip):** assigns the time measured to a unique identification number. In this way it is possible to manage a rapid sequence of finishes extremely efficiently, leaving the matching up of finishes with start numbers for later (see par. C3.1.5.)

**F3 (Eevt – Edit event time):** makes it possible to modify the finish times measured.

**F4 (ST – Same Time):** allows you to assign the same time to more than one start number. It is particularly useful for group finishes. All the start numbers which have to be assigned a finish can be set later. Once again, use S.T. to confirm. To finish the sequence, press ENTER.

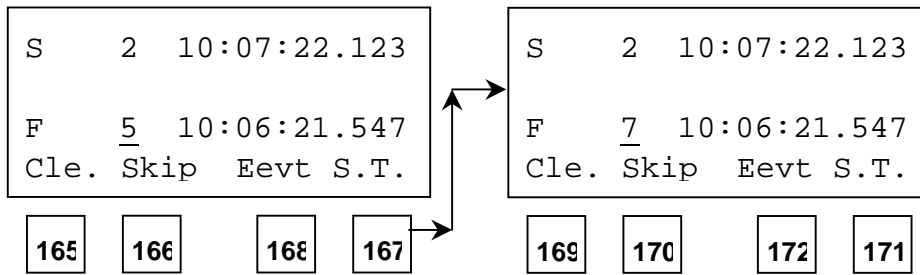

*Fig. C*  
Assignment of the same time to athletes n. 5 and 7:  
Press 5 – F4 – 7 – F4 – ENTER

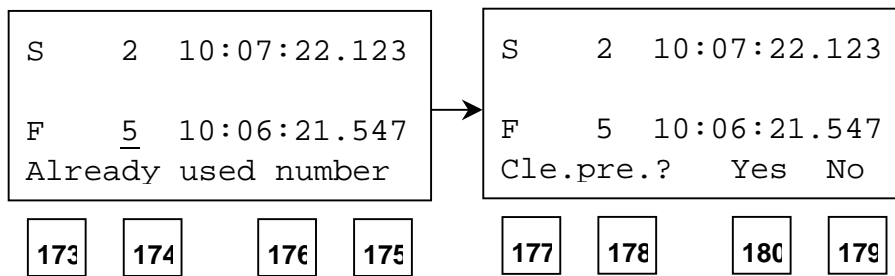

*fig. D*  
If a previously used start number is inserted, confirmation is always requested for overwriting in the memory



```
S    1  10:07:22.123
F
StaN StoN Ask0 SkM→
```

181 182 184 183

LAP

```
S    2  10:07:22.123
L.  1
F    12    34.567
Cle. Skip Nlap ST→
```

185 186 188 187

fig. A

CE

```
S    2  10:07:22.123
L.  1
F    12    34.567
←Eevt
```

189 190 192 191

fig. B

```
S    2  10:07:22.123
L.  1
F    0  10:06:21.547
Cle. Skip Nlap
```

193 194 196 195

fig. C

### 10.2.3 Intermediate time management

If a finish number has been set (with the chronometer showing net running time on line 3), on the arrival of an intermediate time signal the net time for the number previously set is displayed. If the impulse has been generated manually or received via cable from the LAP input, the consecutive intermediate number will automatically be calculated on the basis of the intermediate times previously taken for that particular number

If, on the other hand, the intermediate time signal has been received via radio, the intermediate number corresponds to the one set on the LINKGATE Encoder. In this case Racetime automatically manages the correct sequence of intermediate times, even if several athletes are on the racetrack at the same time. An example may help to clarify this concept: suppose we are timing a race with two intermediate times. The first athlete starts and completes the first intermediate time. Then a second athlete starts and completes the first intermediate time before starter 1 completes the second intermediate time. In this case, Racetime will attribute the first intermediate time signal '1' to the first athlete and when the second intermediate time signal '1' arrives, it will be automatically assigned to the second athlete without the need for any type of action on the chronometer.

**Note:** Lap 14 (Lap E on the Linkgate Encoder) is managed by Racetime 2 in the same way as an impulse received from the keyboard or an input. Therefore the intermediate number will not be '14', but will be calculated automatically on the basis of the previously taken intermediate times. In this way Linkgate Encoder can be used for the transmission of the intermediate time.

The insertion of the start number is requested (or the confirmation of the number already displayed).

**Important:** The assignment of a time to the number displayed can only operate automatically if the function for automatic assignment of net times is on (see par. C3.1.8). If another intermediate time already corresponds to the confirmed starting number and intermediate number of an athlete, a warning will be signalled and you will be able to cancel the previous event.

### 10.2.4 Displaying speeds transmitted by the LINKGATE Encoder

(note: only available on Racetime2 equipped with the optional 'Skitest' software)

The LINKGATE Encoder systems used for the transmission of timing signals (start, intermediate time/times or finish) can also be set to transmit passing speed (for installation instructions, see par. B3.5). In this case, when a timing impulse is received via radio, passing speed data will appear on the second line of the display.

S	2	10:07:22.123
L.	1	58.64Kmh
F	12	34.567
Cle.	Skip	Nlap ST→

If a length for the speed base used was previously set (see par. C10.2.1), speed will be immediately displayed in the selected unit of measurement (see par. C10.2.3). However, if the base length has not been set, base running time will be shown.

197	198	200	199
-----	-----	-----	-----

**NOTE 1 :** Racetime2 only memorises running time so it is always possible subsequently to set or modify both the measurement length base and the speed measurement unit.

**NOTE 2:** The speed base times are displayed with an accuracy of one thousandth of a second. However the acquisition, transmission and memorisation of these times are performed with much higher precision (approximately 1/8000s), which is sufficient to guarantee excellent accuracy in speed measurement even with measurement bases of limited length (3-5 meters).

### 10.2.5 Display of average speeds

(Note : only available on Racetime 2 fitted with the optional software 'Skitest')

S	2	10:07:22.123
L.	1	AV 45.14Kmh
F	12	34.567
Cle.	Skip	Nlap ST→

If a distance has already been set for average speeds, that is, the total length of the course or the length between two intermediate points (see par. C10.2.2 on the subject of the setting of 'average speeds'), the average speed is shown directly in the preselected unit of measurement (see par. C.10.2.3). The letters 'VM' to the left of the speed make it possible to distinguish this speed from that of the radio-transmitted speed.

201	202	204	203
-----	-----	-----	-----

**Note :** if the average speed and the instant (radio-transmitted) speed are acquired simultaneously, only the latter is displayed. Obviously, however, both items of information are printed and memorised.

```

                LCK
S      1  10:07:22.123
                #
F                00:00
StaN StoN Ask0 SkM→
    
```

205
206
208
207

STO

```

S      1  10:09:42.123
                # 1
F                00:00
StaN StoN Ask0 SkM→
    
```

209
210
212
211

LCK

```

S      1  10:09:42.123

F                00:00
Cle. 1 events Yes No
    
```

213
214
216
215

### 10.2.6 LCK key use

The LCK allows you to block one or more timing lines temporarily. Even if, as previously seen, unwanted events can always be annulled later, sometimes it is convenient to block a line in advance to avoid an annoying sequence of annulments (for example, when a whole group of tourists crosses the finishing line...).

You only have to press the LCK key to block the lines on which it is active and these can be configured as you want (see par.). The block is indicated by the presence of the ‘#’ symbol on the second line of the display.

By pressing the LCK key again, you can reactivate the lines. At this point, if at least one event has been discarded, the message ‘Canc. x eventi ? Yes No’ will appear on the fourth line of the display. Answer Yes with F3 to cancel irreversibly the acquired events. Answer No (F4) to deal with the events one by one, deciding whether to annul them or assign them to a competitor.

# 11 INTERPRETATION OF PRINTED DATA DURING TIMING

The removable printer on your Racetime allows you to print event times, net times and speeds during timing. The printing mode depends on the setting of two configurations, which are accessible under the menu heading ‘Config. RACETIME’.

In particular, the printing of event times (that is, the time of day at which the various events -Start- Lap-Stop take place) can be activated/disactivated by intervening on the relevant configuration (see par. C10.1.2 on this subject).

With regard to net times, depending on the setting of the ‘net times print mode’ (see par. C10.1.4) these can be printed after every event (that is, after every lap time or finish) or a synoptic printout can be made, but only after the athlete has finished.

Event times, together with the information that is needed to characterize them, are printed in the following format:

<b>CR</b>	<b>3</b>	<b>STm</b>	<b>12:23:45.678</b>
Operation identifier	Start number serial for skipped	Event time type and id. source	Time (HH:MM:SS.dcm)

The operation identifier (2 characters) shows which operation is coupled with the event time, that is:

- ET event time printout for normal event acquisition
- CA event time cancelation
- SK event time skip - in this case, instead of the start number the unique consecutive identification number is printed
- EE event time editing
- RE replacement (printed together with cancelation when an event time start number is replaced)

The event time type (2 characters) shows if the event time is coupled with a start, intermediate time or finish:

- ST start time (start)
- SP finish time (stop)
- LP intermediate time (lap)

The source identifier (1 character) shows how the event time has been acquired:

- m manually (with the Start - Lap – Stop keys)
- r received via radio
- k manually edited (with event time edit option - Eevt)
- a automatically generated (only for automatic pre – programmed starts)
- e acquired subsequently through download of event times from Linkgate (see cap. C11.3)

The time is always shown with all the digits (even if zeros) and with an accuracy of 1/1000s, with approximation by truncation (remember that RACETIME acquires all times with an accuracy of 1/25000s)

```
CR 4  SPm 11:19:10.985
SK 3  SPi 11:20:46.945
AN 5  STm 11:13:28.432
```

**Net times** together with the information that is needed to characterize them are printed in the following format:

<b>SPT</b>	<b>1:15.28</b>
Identifier of net time type (first two letters) and total/single run identifier	Net time (HH:MM:SS.dcm)

or

<b>L4</b>	<b>58.16</b>
Intermediate (LAP) With progressive Intermediate number	

The identifier of net time type shows if it is a finish time (SP - STOP) or an intermediate time (SL - SPLIT or L - LAP according to whether the time is a partial time calculated from the start or from the previous intermediate time).

The consecutive intermediate number appears only for LAP times.

The total/single run identifier shows if the time is the total of run times (T) or only a single run time (M).

The time is printed only with significant digits and with a number of decimal digits which depends on the selected accuracy of measurement (see par. C10.1.6).

Notice that for the first intermediate event, the LAP time is not printed because it is the same as the SPLIT time. For subsequent laps, SPLIT and LAP times are always printed one after the other. In this way the intermediate time displayed is immediately recognizable by the number which is shown together with the LAP time.

The speed or speed base times are printed in the following format:

**V=138.25km/h**

For printing of speed (only if the length for the base being considered has been set)

or

**Tv=0.234s**

If the running time of the base is printed without its length

Printing immediately follows the net time calculated in relation to the speed measurement base.

The average speed is printed in the following format:

VM=123.45km/h

## 12Group management

```
216.1.1..1   A:Ent
             ./edit groups
B:Clear groups
c:Print groups
```

217    218    220    219

```
Group N.      1
fr.           to
(0 to end input)
```

221    222    224    223

```
Group N.      1
Choice N.     3
fr. 20   to   28
(0 to input)
```

225    226    228    227

It is possible to define up to a maximum of 98 groups, subdivided in turn into 8 subgroups each.

Groups are used both when working in the 'Group starts' mode, to define the numbers assigned to the groups at the start, and when printing rankings by category.

For the definition of groups, select 'B:Ins./group printouts' from the main menu (F2) and then 'A:Ins./edit groups' from the submenu (F1). At this point, suppose you wish to define the following groups (categories):

```
Group 1      start numbers 1 to 10
              start number 15
              start number from 20 to 28
```

```
Group 2      not used
```

```
Group 3      start numbers from 40 to 50
```

You must then press the following sequence of keys:

1, Enter, 1, Enter, 10, Enter, 15, Enter, 15, Enter, 20, Enter, 28, Enter, 0, Enter (end of group 1)

3, Enter (group 3 setting, group 2 is not used)

40, Enter, 50, Enter, 0, Enter, 0, Enter (to quit the setting).

You can check the correct setting by selecting 'C: Print groups' (F3) or by viewing the groups you are interested in by means of 'A:Ins./edit groups'.

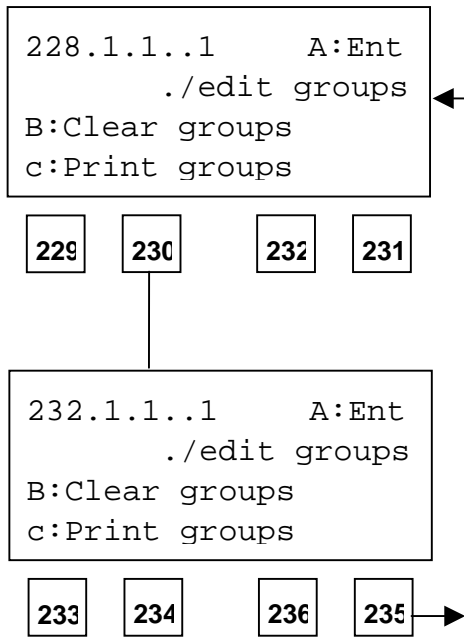

To cancel completely the current setting for groups select 'B:Cancel groups' (F2). To cancel one group only, insert 0 in choice 1 of the group to be canceled.

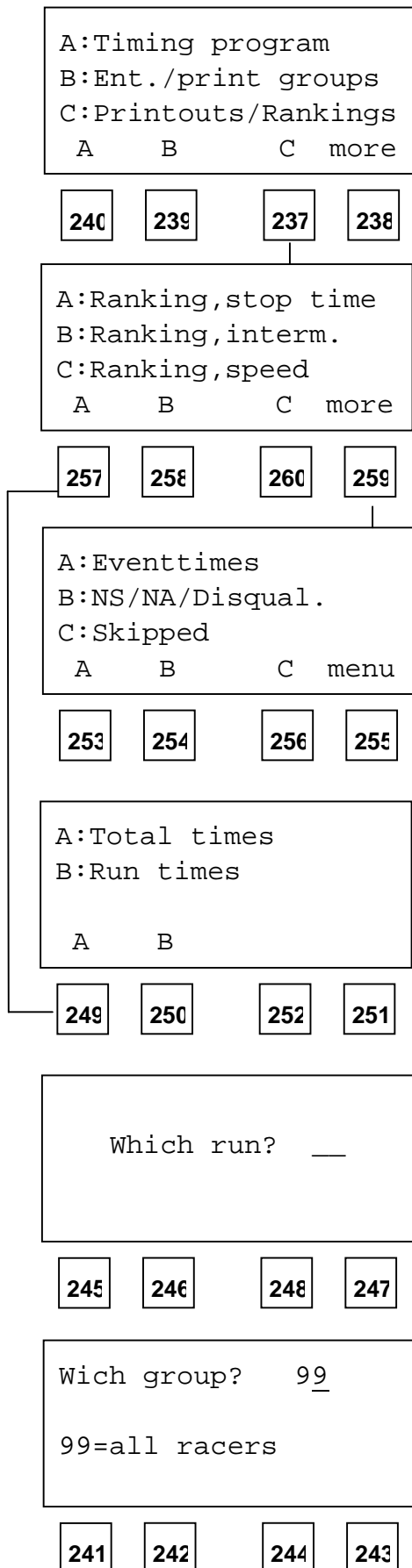

## Printout and rankings management

Racetime 2 is equipped with such powerful management of rankings that it can almost *totally* replace the Personal Computer in subsequent data revision. To access the rankings menu, press F3 (Rankings printouts) from the first screen of the main menu.

### 12.1 RANKINGS FOR FINISH TIMES, INTERMEDIATE TIMES AND SPEED

From the menu it is possible to choose from rankings calculated on the basis of total or single run finish times, intermediate times (split total, split run or split lap), or the running speed acquired by the LINKGATE Encoder.

By total split time, we mean the run times for runs prior to the one selected added to the time between the start and the selected intermediate time.

All the rankings can be limited to a particular group or can be extended to all the start numbers. (The latter choice can be selected by inserting 99 in the screen for group settings). The rankings can be viewed on the display or printed out.

Total time refers to the sum of the single run times up to the selected run; it only exists if the athlete has, in fact, the times of the runs prior to the selected one.

Enter the chosen run number.

If you select a group from those set (see chap. C4), the ranking will be calculated only on the basis of the start numbers belonging to the group selected. Group 99 is set as default and includes all start numbers.



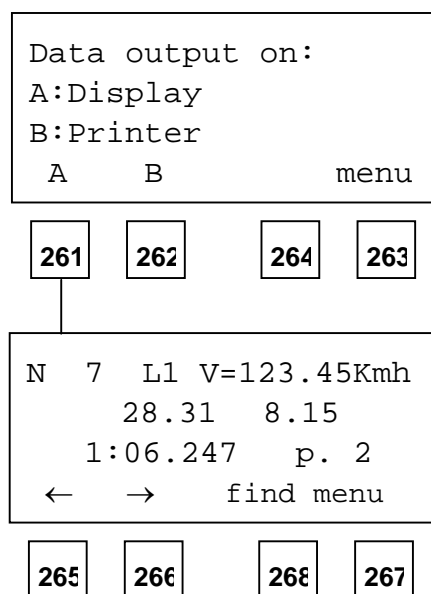

fig. A

### 12.1.1 Viewing on the screen

If you choose F1 to view the display, the screen display in Fig.A will appear. In this display:

N = number of athlete

L = intermediate number to which speed and split/lap times refer.

split time lap time

time on the basis of which the ranking has been calculated (total, single run, split, lap or speed – according to choice)

position

With the function keys and the  $\uparrow\downarrow$  keys, it is possible to move around inside the ranking. In particular:

$\leftarrow\rightarrow$  (F1- F2): allow you to go from one position in the ranking to the next or previous one

search (F3): you are asked for a start number and, after confirmation, the times and position of that number are displayed

$\uparrow$  and  $\downarrow$  keys: allow you to view in succession all the intermediate times and speeds obtained for an athlete currently shown in a ranking. Note that the time and position shown on the third line do not change when you use these keys as the ranking was calculated on the basis of these times. In addition, if only a net time has been taken for an athlete in the ranking, nothing will happen when you press  $\downarrow$  and  $\uparrow$ .

### 12.1.2 Printing the ranking

If you choose 'data output on: printer' (F2 key), a new menu will be shown on the screen:

If you choose 'Print selection' (F1), apart from the athlete's position and number, only the times requested from the options of the rankings menu (for example, only the total times for the second run) will be printed.

If you choose 'Complete print' (F2), on the other hand, you will get a synoptic printout with all the net times of every athlete, together with any speeds, ordered according to the time on the basis of which the ranking has been calculated. This print mode is particularly useful in training as it makes it possible to have a complete picture of how the run went.

The following example gives the final positions for the same run presented in both modes.

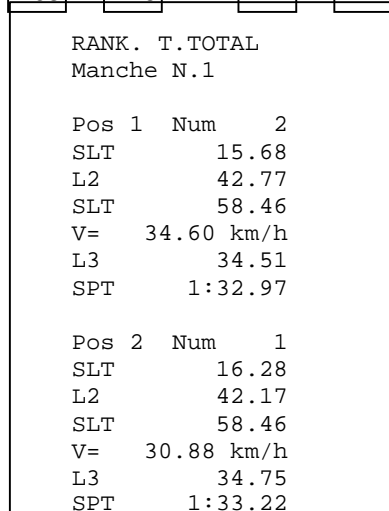
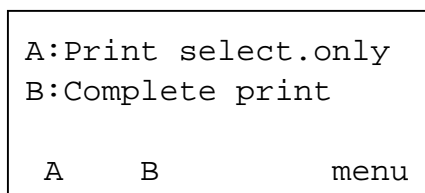

Complete print

Print select

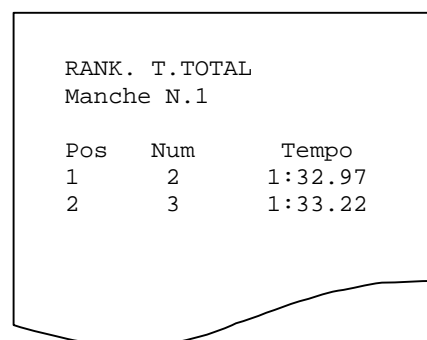

A: Ranking, stop time  
 B: Ranking, interm.  
 C: Ranking, speed  
 A B C more

281 282 284 283

A: SPLIT total  
 B: SPLIT run  
 C: LAP  
 A B C more

285 286 288 287

Laptime number?    

289 290 292 291

Which run?    

293 294 296 295

Which group? 99  
 99=all racers

273 274 276 275

Data output:  
 A: Display  
 B: Printer  
 A B menu

277 278 280 279

## 12.2 INTERMEDIATE TIME RANKINGS

Total SPLIT time refers to the time taken by the athlete from the start of the first run to the intermediate time being considered. Single run SPLIT time refers to the time taken from the start to the intermediate time of the single run being considered. LAP refers to the time taken from the start to the first intermediate time, and from the first intermediate time to the finish.

It is possible to ask for the ranking of a particular intermediate time.

Enter the single run number chosen

If you select one of the set groups, the ranking will be calculated only for start numbers belonging to the selected group. Group 99 is set as default and includes all start numbers.

Press **F1** to display an output  
 Press **F2** to print the ranking

### 12.3 SPEED RANKINGS

```
A:Ranking,stop time
B:Ranking,interm.
C:Ranking,speed
A      B      C  more
```

297 298 300 299

```
A:Radio speed
B:Average speed
A      B      menu
```

301 302 304 303

Select 'A: Radio Speed' if you want to calculate the ranking of the speeds transmitted by the Linkgate system. Select 'B: Average Speed' for the ranking of the average speeds from Start to Stop or from Lap to Lap.

```
Laptime number? =
(0=Start, 15=Stop)
```

309 310 312 311

```
Laptime number? _
(0=Di. Start-Finish)
```

305 306 308 307

Speed ranking can be referred to a particular intermediate time. Set 0 to obtain the ranking for the average start-finish speed. The ranking is calculated only if the distance has been previously set (par. 10.2.2 on page 55).

You can get a ranking for speed measured at a particular intermediate time (1...14), at the start (0) or at the finish (15)

```
Which run? _
```

313 314 316 315

Enter the single run number chosen

If you select one of the set groups, the ranking will be calculated only for start numbers belonging to the selected group. Group 99 is set as default and includes all start numbers.

```
Which group? 99
99=all racers
```

317 318 320 319

```
Data output on:
A:Display
B:Printer
A      B      menu
```

321 322 324 323

Press F1 to display an output  
Press F2 to print the ranking

## 12.4 PRINTING EVENT TIMES, NP, NF, DISQUALIFIED, SKIPPED

By choosing ‘other’ (F4) from the first page of the rankings menu, you can access a series of auxiliary printouts.

Printing event times: the event times (that is, the starting times of the various events) are printed in the order in which they were acquired. For instructions about each event time, see par. C1.12

Printing non-starters/non-finishers/disqualifications: non-starters, non-finishers and those disqualified are shown divided according to the various runs and with the time at which they were declared non-starters, non-finishers or in the case of those disqualified, at the starting time.

Using the ‘NS’ and ‘NF’ functions from the timing menu (see par. C1.2 and C1.1), you can note that the non-starters and non-finishers are only the start numbers declared to be such.

Printing skipped: skipped events not yet assigned to start numbers are shown together with the event times.

```
A:Ranking, stop time
B:Ranking, interm.
C:Ranking, speed
  A      B      C  more
```

325

326

328

327

```
A:Eventtimes
B:NS/NA/Disqual.
C: Skipped
  A      B      C  menu
```

329

330

332

331

```
Data output on:
A:Display
B:Printer
  A      B      menu
```

337

338

340

339

```
Which run?      ___
(0= all runs)
```

341

342

344

343

```
Printing...
```

333

334

336

335

Press **F1** for display output

Press **F2** for printer output

Indicate the run (0 or empty for all runs) and press ENTER to print.

When you have finished printing, you will automatically return to the first menu.

## 13AUTOMATIC STARTS

```
A:Autom.start
B:Disqualif.
C:Synchronize
A   B   C   more
```

345 346 348 347

```
A:Ent./edit sequence
B:Clear sequence
C:Print sequence
A   B   C   menu
```

349 350 352 351

```
N 1 (0=end) run
fr. to s.
st.time
timestep (s)
```

353 354 356 355

RACETIME2 enables you to set a sequence of programmed starts at pre-established times. This setting is possible in both ‘Single start’ or ‘Group start’ mode.

From the second display screen of the main menu press F1 (Autom. start) to go to the automatic start submenu. Press F1 (Ent./edit sequence) to insert new pre-set start sequences or to edit them.

**F1:** Allows you to insert new pre-set start sequences or to edit them.

**F2:** Cancels all set sequences (you are asked to confirm)

**F3:** Printout of only the automatic starts which have yet to take place

**F4:** Returns you to the main menu

Now the following settings have to be made:

- the number of sequences (this is proposed automatically)
  - the run the start sequence refers to
  - the number of the first athlete (or group) to start
  - the number of the last athlete (or group) to leave
  - the incremental step of the start numbers within the sequence
- If, for example, you choose numbers 1 to 11 with an increment of 2, the resulting starting sequence will consist of numbers 1,3,5,7,9,11. If you choose an increment of 1, the sequence will include all of the eleven starting numbers.
- the time of the first start
  - the interval, in seconds, between one start and the next

It is possible to insert up to a maximum of 16 sequences. These can overlap partially or totally.

To end the setting, you need only insert 0 (zero) in the first field (sequence number). To cancel a single sequence, insert 0 (zero) in the field for the number of the first athlete (or group) to start.

Important: automatic starts cannot take place if the times set in the sequences precede the time set on the chronometer. It is therefore necessary to temporarily change the synchronization of the clock if you want to generate retroactive sequences.

Example. Start from N°1 to N°8 with step=2 at 12.00 with an interval of 10 sec.:

```
Time 12:00:00   no. 1 starts
Time 12:00:10   no. 3 starts
Time 12:00:20   no. 5 starts
Time 12:00:30   no. 7 starts
```

```
N 1 (0=end) run 1
Fr. 1 to 8 s. 2
st.time 12:00:00.000
timestep (s) 10
```

357 358 360 359

# 14DISQUALIFICATIONS/REINSTATEMENTS

```
A:Autom.start
B:Disqualif.
C:Synchronize
A    B    C    more
```

**361**   **362**   **364**   **363**

```
Disqualification
Num.  _  Run      =
Toggle  other menu
```

**365**   **366**   **368**   **367**

```
Disqualification
Num. 1  Manche  1
      qualified
Toggle  other menu
```

**369**   **370**   **372**   **371**

```
Disqualification
Num. 1  Manche  1
      diqualified
Toggle  other menu
```

**373**   **374**   **376**   **375**

Insert the run and the name of the athlete to be disqualified or reinstated; confirm the numbers with Enter (use F4 to go straight back to the menu).

When you have identified the athlete and run, press **F1** to disqualify or reinstate.

**F3** to insert another athlete code or run  
**F4** to return to the menu

# 15 SYNCHRONIZATION

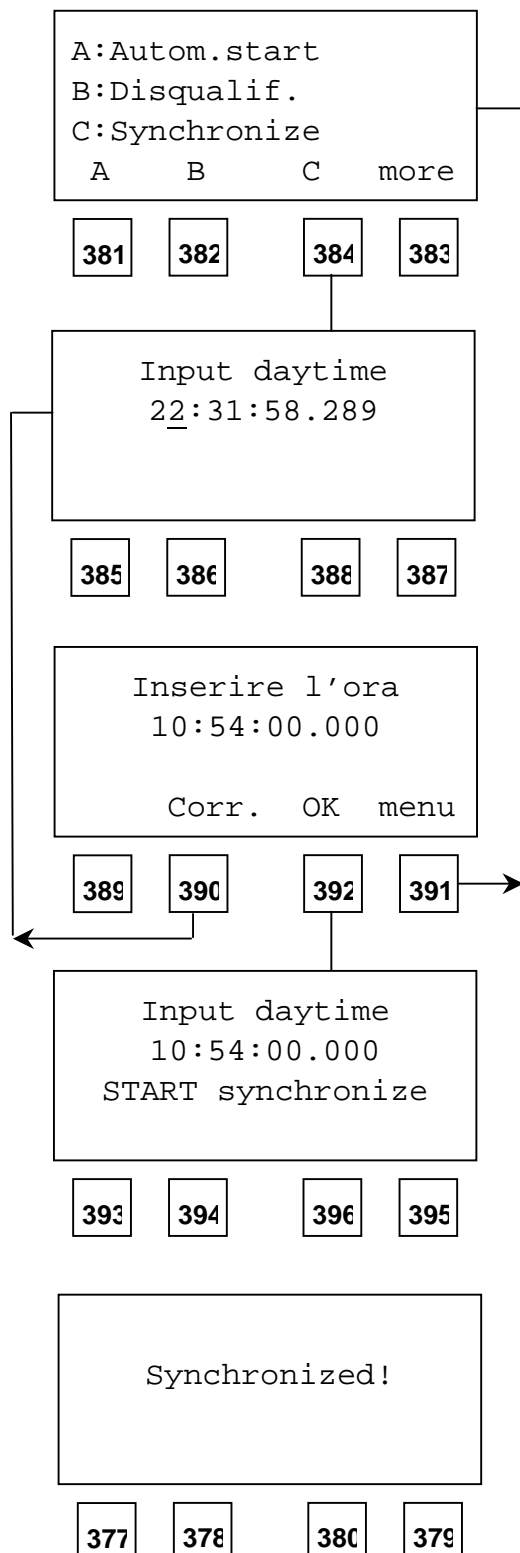

To set the exact time:

Example: to synchronize RACETIME at 10.54 AM  
Press:

**1 0 ENTER 5 4 ENTER 0 ENTER 0 ENTER**

To correct press F2, otherwise press F3.

Press START to synchronize RACETIME at the set time.

After a message of confirmation you are automatically returned to the first menu.

## 16OFF-LINE DATA TRANSMISSION

```
A:Send stored data
B:LINKGATE download
C:Signal level
A   B   C  more
```

401

402

404

403

```
Which run?   _
(0= all runs)
```

405

406

408

407

```
Which group?  99
99=all racers
```

409

410

412

411

```
Data to transmit?
RT.  EvT.  NSNASQ menu
```

413

414

416

415

```
Wait, please...
```

397

398

400

399

It is possible to transmit stored times to a PC at any moment. To do this, select ‘Trans. Data’ (F1) from the third screen of the main menu.

Insert the run number.  
If you choose 0, data for all the runs will be transmitted.

If you select one of the groups set, ranking will only be calculated for start numbers belonging to the selected group. Group 99 is set as default and includes all numbers.

Now you can choose whether to transmit only the event times or the net times. In both cases times are transmitted according to the protocol described later. Note that the data is transmitted in ‘binary’ form and not as text. For a detailed description of transmission protocol, see Appendix B.

When all the data has been transmitted, you return automatically to the first menu.



# 17 SYSTEM CONFIGURATION

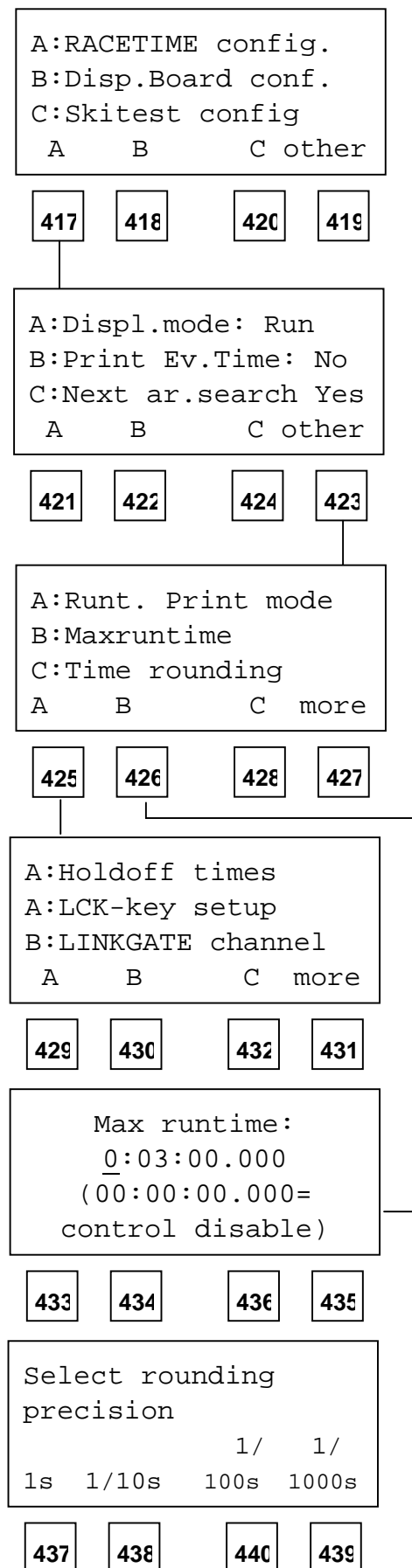

## 17.1 RACETIME CONFIGURATION

The configuration menu enables you to modify numerous settings that affect the way Racetime2 functions. Remember, however, that if you choose to cancel the configuration when switching on the machine (see chap. C2.3) or to reset a configuration and select one more suitable for your timing session, all of the parameters will be set to values which are normally the most appropriate in the majority of cases.

### 17.1.1 Time display mode

Allows you to choose whether to view total times, single run times or lap times on the screen display and displayboard. Choose with the F1 key.

### 17.1.2 Event times printout

Using the F2 key, you can activate/disactivate the automatic printing of event times when the various events (Starts – Lap - Stop) take place.

### 17.1.3 Automatic finish search

If this function is activated, during timing Racetime2 will automatically show the athletes’ net times on the third line of the screen after they have started. If it is deactivated, you should activate the display by calling up a competitor with the ‘Nsto’ key (F2) or by pressing the ↑ ↓ keys. See also par. C3.1.2 for further explanations.

### 17.1.4 Net time print mode

By selecting this function with F1 you access a submenu. You can choose to print net times after the acquisition of each event (that is, after every intermediate time and after the finish), or ‘synoptically’ after the athlete has reached the finish line. This second choice is particularly convenient for competitions such as alpine skiing, uphill motor-racing, downhill mountain-biking and other competitions with individual starts and short durations while printing after each event is more convenient in sports such as cross-country skiing, marathons and road cycling.

### 17.1.5 Maximum time

With this option, you can insert a maximum single run time above which the competitor will automatically be expelled and therefore no longer timed. Note however that it is still possible to ‘reinstate’ a competitor with times greater than the maximum simply by modifying the maximum time or by **deactivating** the function. To deactivate the maximum time, set the time at 00:00:00.000

### 17.1.6 Measurement accuracy

You can select measurement precision only for net times between one second, 1/10s, 1/100s, and 1/1000s.

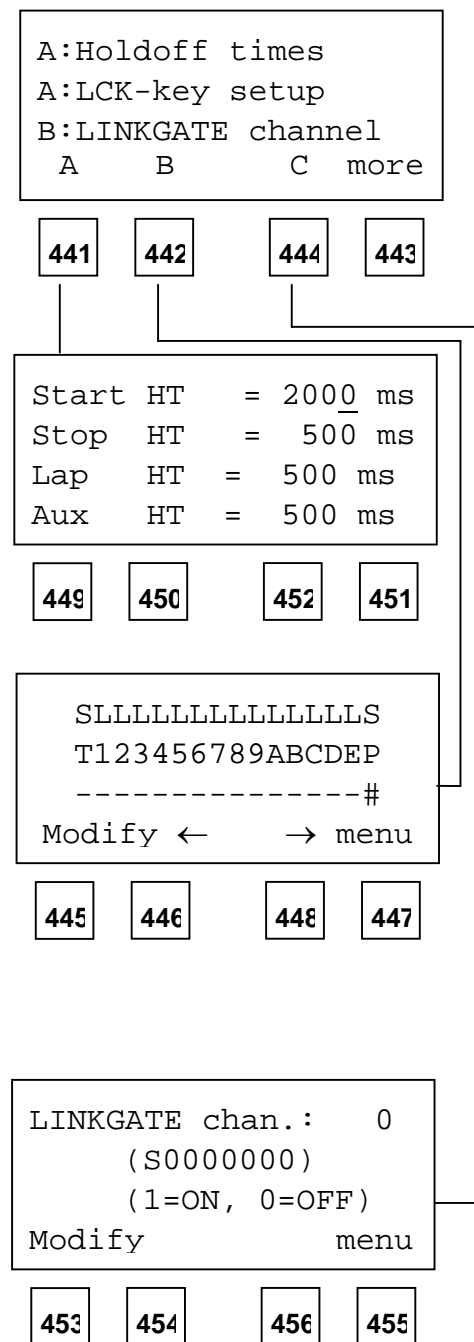

### 17.1.7 Modifying ‘dead’ times

Allows you to modify the disactivation times of inputs after the acquisition of an event. This can be done separately for the Start, Lap, Stop and AUX lines (the AUX line is only used in the PC On-line program, see chap. E in the manual).

### 17.1.8 Activating the LCK key

Choose this option to modify the lines on which the LCK key is active (see also par. C3.2.6). With the arrows (F2 and F3), it is possible to move the cursor from one field to another. With ‘Edit’ (F1) the blocking of the line on which the cursor is positioned can be activated or deactivated – beginning from the Start (on the far left), passing through Laps 1...14, to the finish (on the far right). The presence of the block is indicated by the # symbol. Note that the lap times refer to the signals transmitted via radio using the LINKGATE system. The activation of the block on LAP 14 (E) also block LAP signals coming from the keyboard or the inputs.

### 17.1.9 LINKGATE channel

Allows you to modify the LINKGATE system work channel so you can move to another channel if necessary. On the display, the setting indication for the ‘dip switch’ located on the LINKGATE Encoder will appear. The first selector does not affect channel selection (its function is to select signal length and is therefore shown with the letter ‘S’). Next, the status of the other switches is shown (1=switch up, 0=switch down). To modify the setting press ‘Edit’ (F1). Remember once again that it is absolutely essential that Racetime2 and the LINKGATE Encoder are set on the same channel (see chap. B3).

```
A: Baudrate:      9600
B: Format:        ASCII

A      B          more
```

**457**   **458**   **460**   **459**

```
A: Printer      On
B: Keyb.beep   On
C: Initialize  Setup
A      B      C  menu
```

**461**   **462**   **464**   **463**

### ***17.1.10 Setting of serial transmission parameters***

*ATTENTION : this configuration is present only on versions 20.x.yy, 21.x.yy, 22.x.yy and 24.x.yy.*

Serial transmission velocity is modified by pressing F1 (1200, 2400, 4800 or 9600 bit/s).

Pressing F2 allows you to choose between binary and ASCII for the format of transmitted data. The transmission protocols for the two modes are given in Appendix B.

### ***17.1.11 Activation/disactivation of the printer and of acoustic signalling when keys are pressed***

To modify the settings press keys F1 and F2 respectively

### ***17.1.12 Initialization of configuration***

Press F3 and then confirm to go to the configuration options menu (par. C0.5)

## 17.2 SKITEST CONFIGURATION

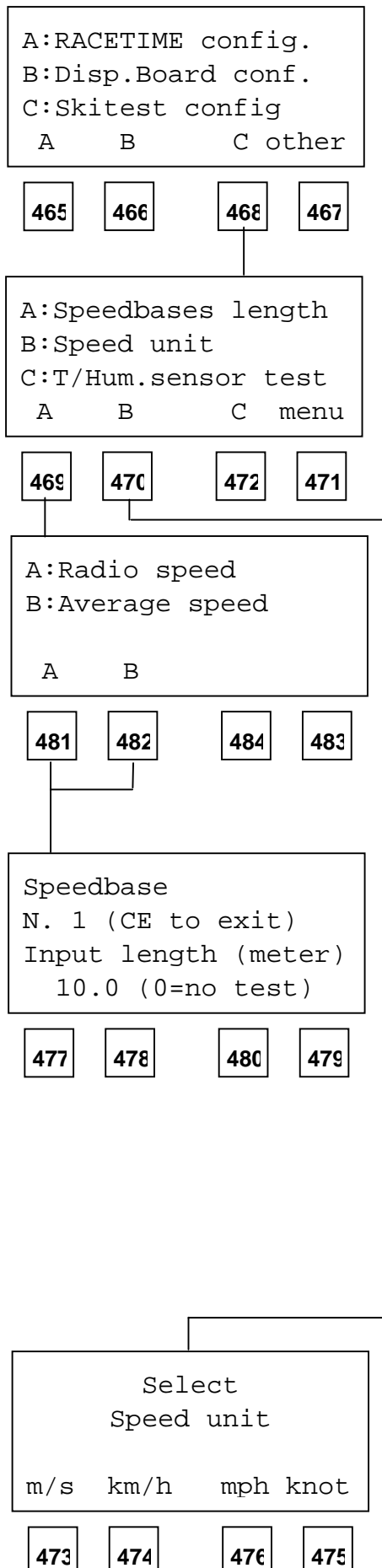

*(Note: available only on Racetime2 equipped with the optional ‘Skitest’ software)*

To access the Skitest configuration submenu, with F3 select ‘Config. Skitest’ from the third screen display of the main menu. From this menu, you can modify the parameters that affect the speed measurement and climate data measurement functions.

### 17.2.1 ‘Radio’ speed base length

Insert the speed base lengths that you intend using. Specify the measurement base number (0 = Start base, 1...14 Lap bases, 15 = Stop base). Next, key in the length of the base (first meters, up to a maximum of 65000, then centimeters). A value of zero indicates that on the base concerned, the speed does not need to be calculated.

**Note:** you can also insert a speed base length afterwards as Racetime2 only memorises base running time. The speed is calculated at the moment of display.

To quit this function press CE.

### 17.2.2 ‘Average’ speed base length

Insertion of speed base lengths for taking average speeds. By average speeds is meant the speed taken to cover the various stages of the course.

The measurement base number refers to the various stages timed. If, for example, we suppose that the course is 1000m long and that there are two intermediate points, the first 200m from the start, the second 500m after the first intermediate point, the distances will be set as follows:

N. 0 ⇒ start - finish distance, 1000m

N. 1 ⇒ start - intermediate 1 distance, 200m

N. 2 ⇒ intermediate 1 - intermediate 2 distance, 500m

N. 3 ⇒ intermediate 2 - finish distance, 300m

(=1000-200-500)

Also in this case the distances can be inserted or modified after the times have been acquired.

### 17.2.3 Speed measurement unit

With the function keys choose the measurement unit in which speeds must be shown from, m/s, km/h, mph and knots (nautical miles per hour).

T. Air	=	-1.1 °C
T. Snow	=	-3.2 °C
Hum. Snow	=	78 %
60m menu		

485

486

488

487

#### ***17.2.4 Temperature and humidity probe tests***

It is possible to view the values for air and snow temperatures and air humidity if the relevant measurement probes are connected.

Press **F1** to print the values displayed, together with the time of day

Pressing **F2** allows you to set an interval in minutes for automatic data printing. The maximum value that can be set is 720 minutes, or 12 hours. Automatic printing continues at regular intervals until you quit the function or until the time interval is set to zero.

To quit the function, press **F4**.

When the probes are not connected, Racetime2 shows an error message.

## 17.3 DISPLAYBOARD CONFIGURATION

```
A:RACETIME config.
B:Disp.Board conf.
C:Skitest config
A      B      C other
```

489 490 492 491

```
A:Type: Microgate
B:Num.of Disp.B. 1
C:Advertising: Off
A      B      C menu
```

493 494 496 495

Select 'B : Displayboard Config.' from the second display of the main menu to access displayboard configuration.

### 17.3.1 Displayboard type

ATTENTION : this configuration is only present on versions 20.x.yy, 21.x.yy, 22.x.yy and 24.x.yy.

Select the type of displayboard you wish to connect to the chronometer Racetime 2. Remember that for each displayboard the appropriate connection cable, available from Microgate, must be used. For the connection of the Telecron displayboard it is also essential to use the code \$ACC050 interface.

#### 16.3.1.1 PC-ONLINE Output

It is possible to choose the 'PC-Online' displayboard type. In this case, On-line output of data is activated, as explained in appendix 2.3 on p.110.

### 17.3.2 Displayboard number

This option is only active if Microgate displayboards are used. Press F2 to select the number of displayboards (one or two). If only one displayboard is used, only the time (running and final) appears.

If you choose to work with two displayboards, a Master displayboard and a Slave displayboard are required (or alternatively, a second Master set to display column 9 as first column – see the Tabmicro manual on this subject). The competitor number and the time are displayed simultaneously.

### 17.3.3 Advertising

If a Microgate displayboard is used, it is possible to activate the display program (Prog. 1) previously memorised in the displayboard itself. For further details, see the instructions for the Microgate  $\mu$ TAB displayboard on this subject. Pressing F3 will deactivate the display program and restore the normal function program (Prog. 0) on the displayboard

# 18 OTHER FUNCTIONS

## 18.1 RECHARGING BATTERIES

```
A:Time calculator
B:Battery charge

A      B      menu
```

```
497  498  500  499
```

```
Trickle ch.
A:Rep.charge/disch.

A      menu
```

```
501  502  504  503
```

The recharging of Racetime2’s internal batteries is managed entirely by the microprocessor which controls all of the chronometer’s functions. Consequently, it has been possible to implement a recharge control which guarantees maximum battery efficiency at all times, at the same time prolonging the chronometer’s operating life.

To recharge the batteries, connect a 12 - 20 Volt DC power source (normally you will use the AC/DC adapter supplied in Racetime’s kit) to the appropriate power point (chap. A2). If the chronometer is off, information on the current status of the battery recharge management functions will be immediately shown on the display.

Specifically, the following messages will appear on the first line of the display:

Status/message	Function description	LED status
Maintenance	the chronometer is supplied by an external power source and, concurrently, the batteries’ efficiency is maintained by a week recharge current	Brief blinking every four seconds
Discharge	at the beginning of a recharge cycle, the batteries are completely run down before being recharged	LED continuously lit
Recharge	recharge in progress. On the first line of the display, the time still to go until the end of recharge is shown	Blinking LED

```
Discharging...
A:Immediate charge
B:Break process

A      B      menu
```

```
505  506  508  507
```

If you see the letters ‘Vext. Ins’ blinking on the first line of the display, this means that the voltage supplied at the recharge/supply input is insufficient. **ATTENTION:** when external power is insufficient, recharging is interrupted and so cannot be completed correctly and within the time anticipated.

```
Charging      7:00:00.
A:Rep.charge/disch.
B:Break process

A      B      menu
```

```
509  510  512  511
```

If the chronometer is in ‘Maintenance’, press ‘A:Rep.charge/disch.’ (F1) to begin a new charge cycle. This will start the running down of the batteries. The duration of this discharge phase is variable and depends on how fully the batteries are charged. (The time needed to discharge can last up to four hours).

After discharging the batteries, Racetime2 will automatically begin to recharge; this takes seven hours. After recharging, the words ‘End Charge – OK’ indicate that the process has been correctly completed. If, however, battery malfunction has caused premature interruption of charging, the messages ‘Err. Batteries – LV’ (insufficient battery voltage) or ‘Err. Batteries –HV’ (battery voltage too high) will appear. During recharging the time needed to complete the process will appear on the display.

During discharging, it is possible at any time to go straight over to charging by pressing ‘A: Rep.charge/disch.’ (F1). This will shorten the time needed for recharging. However, you are advised not to charge the batteries without first discharging them as this could cause a reduction in the capacity of the batteries (memory effect).

At any moment, you can interrupt discharging/recharging by pressing ‘B: Break process’ (F2).

**Note 1:** If the external power source is cut off during charging, charging will be interrupted and resumed from the same point it had reached before being interrupted once the power source has been restored. This represents an extra guarantee of the reliability of the recharge system.

**Note 2:** During discharging and recharging, Racetime2 becomes slightly but noticeably warm. This is absolutely normal.

It is also possible to access these functions when the chronometer is on. In this way, you can begin to recharge the device without interrupting a timing session.

To access recharge management, choose ‘A:Battery charge’ from the fourth screen display of the main menu.

### 18.1.1 Low batteries warning

When the batteries have nearly run down completely and an external power source is not connected, the LED lights up and remains lighted. From the time the LED lights up, you still have a considerable amount of time to finish your work, nearly two hours without using the printer (but much less if the printer is used frequently). If it is not possible to quickly connect the chronometer to an external power source, it might be better to disconnect the printer (see par. C10.1.11) in order to increase remaining autonomous functioning.

Remember that when fully charged the batteries can be used continuously for approximately 8-9 hours, if on average a printout is made every 20 seconds. Length of duration may be less in particularly harsh climatic conditions or if the batteries are worn out. It is absolutely normal for battery efficiency to decline after approximately 500-1000 recharge cycles. If you notice a significant reduction in the duration of the batteries, please contact Microgate for replacements.

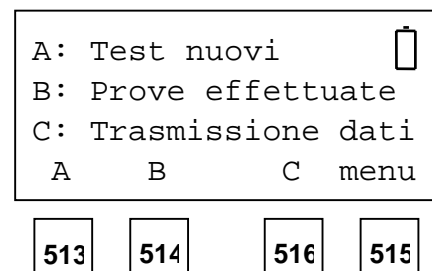

## 18.2 MEMORY LIMITS

Racetime2’s memory is large enough to store 1350 events. In the case of a single run with individual starts and with only start, this is equivalent to the capacity to store about 650 athletes. If the memory’s limits are exceeded, a message appears on the display; it is possible to continue with timing, but the data will not be stored.



### 18.3 RECEIVING DATA FROM LINKGATE

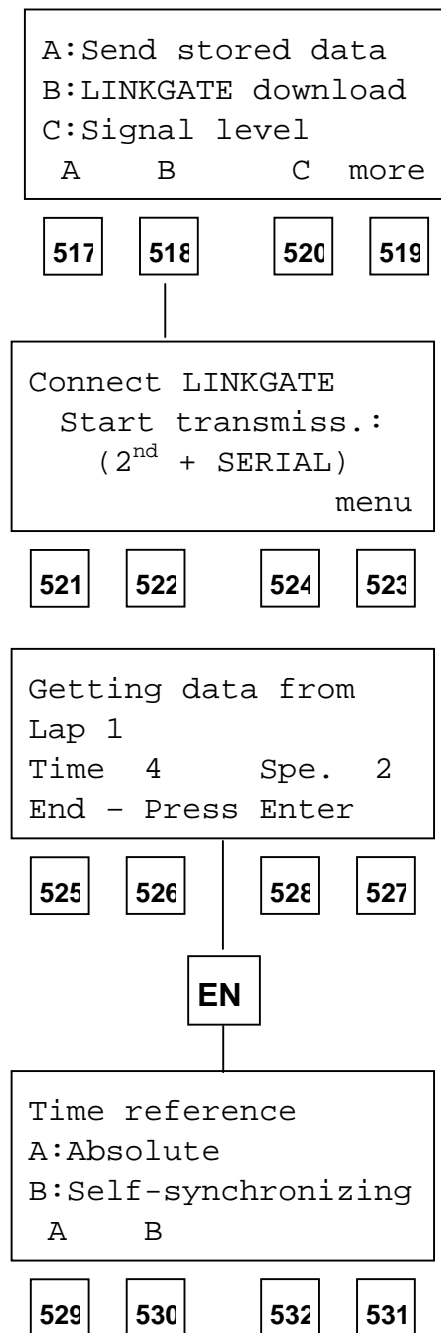

Microgate LINKGATE Encoder’s device for radio transmission of impulses allows you to transmit all the event times and speeds obtained during timing (up to a maximum of 256 times and 256 speeds) to Racetime2. This possibility enhances reliability as it enables you to ‘retrieve’ later any times which for whatever problem have not been transmitted.

To access the data transfer function, select ‘B :Rec.data LINKGATE’ (F2) from the fourth screen display of the main menu. Then connect the LINKGATE Encoder with the cable specified for this (par. B3.9).

**IMPORTANT** : the LINKGATE Encoder device must not be connected to the socket during data transfer from the LINKGATE Encoder.

Press F1 to choose ‘Recep’ and then begin transfer. (Press ‘2<sup>ND</sup>’ on LINKGATE Encoder and, keeping it pressed down, press ‘SERIAL’).

Within two seconds two counters will appear on the screen to indicate the number of times and speeds actually transmitted.

When you have finished transmission, if you press Enter another menu will appear.

If you choose ‘Absolute’ (F1), the event times are simply transferred and shown in the same way they were acquired. It is therefore essential for the LINKGATE Encoder device and Racetime2 to have been synchronized (see par. C6 and B3.8) before the beginning of the timing session (if you do not want to have to make a laborious series of calculations and corrections later.....).

If you choose ‘Autom.Synch.’ instead (F2), the two devices are synchronized later, when the data are transferred.

In this way the times will be restored to the correct values even if the LINKGATE Encoder and Racetime2 were never synchronized. This second option is usually the most convenient one. However, you must not switch off Racetime2 or change its synchronization in the time between the end of the timing session and the moment when data transfer is made. Also, it is better to transfer data immediately after the end of the timing session so as to reduce the deviation caused by the inevitable slight divergence between the base times of the two devices (see the technical specifications of the LINKGATE Encoder and Racetime2 for an estimate of possible divergences).

```

Printing of
Received times?

Yes   No
    
```

533    534    536    535

The times and speeds transferred by the Linkgate Encoder can be printed to facilitate the assignment of times.

```

<ST N   1 110345.789
L 1 N   0 110451.136
>SP N   1 110513.289
←   → (0=Skp) menu
    
```

537    538    540    539

*In the example, a Lap signal follows the start of athlete N°1 and precedes his/her finish. It is therefore probable that the acquired event time refers to competitor 1's lap time*

After choosing the time reference, you will automatically enter the assignment function. With this operation, you can assign an event time transferred from LINKGATE Encoder to an athlete's starting number for a certain run. The transferred times are shown on the second line of the display. The event times immediately before and immediately after the acquired time are shown on the first and third line respectively. In this way, it is easier to 'orientate yourself' amongst the times and find the time or times you wish to retrieve. To pass from one time to the next without assigning them, press Enter. To run backwards and forwards through the acquired times, press → (F2) or ← (F1). To assign a time to a start number, insert the number directly, confirm with ENTER and then insert the run number on the fourth line of the display. If you try to assign a time already used, the chronometer will show a warning signal.

**Note 1:** it is better to have an approximate idea of when the missing event time or times took place. To this end it could be useful to print out the event times beforehand.

**Note 2:** for reasons of space, the event times are shown with only one dot separating the thousandths of a second. The display format is hours, minutes, seconds, thousandths of a second.

## 19RADIO SIGNAL QUALITY

```
A:Send stored data
B:LINKGATE download
C:Signal level
A      B      C  more
```

541 542 544 543

```
Ready to receive !
menu
```

545 546 548 547

```
Receiving...
Start
```

549 550 552 551

*After receiving signal*

```
Ready to receive !
Start
Channel 4      S=100%
CHANNEL DIFF.! menu
```

553 554 556 555

Racetime2’s software is equipped with a function for the evaluation of the quality of the radio signal received. This *utility* is especially useful when the radio signal is considerably disturbed and it is therefore necessary to evaluate the transmission’s degree of reliability.

To access the function, select ‘C : Quality signal’ (F3) from the fourth screen display of the main menu. The words ‘Ready to receive!’ indicate that the system is waiting to receive a radio transmitted impulse. 3 seconds after the start of signal reception (during reception ‘Reception in progress....’ is shown), the channel of the signal received and the quality of the signal in percentages are shown on the display. Obviously the closer the percentage is to 100%, the better the quality. Values greater than 40% are to be considered ‘safe’.

If the channel set on the LINKGATE Encoder (see par. C10.19a and B3.9) does not coincide with the channel set on Racetime2, the message ‘DIFF. CHANNEL’ (different channels) will appear on the screen. If reception is particularly difficult, several stratagems can be attempted:

- place both the transmitting and receiving radios (the radios connected to the encoder) in an elevated upright position
- if the disturbance is generated by interference from other transmitters operating on the same channel, change the frequency you are working on
- use more efficient antennas (1/4 wave or 5/8 wave, instead of the normal ‘charged’ type), especially for transmission radios

**Note:** testing of signal quality should preferably be made with the ‘short-long’ selector on the Linkgate Encoder (see also par. C3.2) set to ‘long’ (L). If the selector is on ‘short’ (S), the maximum value indicated by the test is 20%.

## 19.1 TIME CALCULATOR

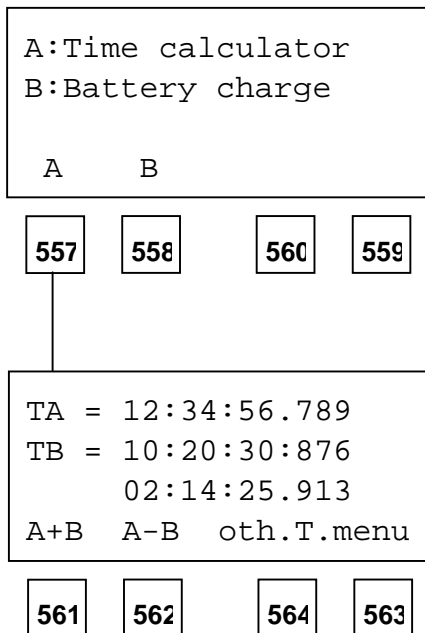

To access the calculator function, select 'A : Calculator' from the third display of the main menu.

Key in the first time you wish to add or subtract (TA); then key in the second time (TB).

Select the operation to be carried out on the two terms:

**F1 (A+B)** adds the two times

**F2 (A-B)** subtracts time B from time A

To modify the times, press F3.

If you have to modify only one of the times, the time not to be modified can be 'skipped' by pressing CE to avoid pressing ENTER four times.

**Note 1:** the times are 'normalized' at 24.00 hours; for example, 2:00:00.000+23:00:00.000 = 1:00:00.000 and not 25:00:00.000 !!!

**Note 2 :** be careful when keying in the thousandths, especially if the times to be added or subtracted are expressed with an accuracy of tenths or hundredths; for example, to insert the time 1:02.84 (one minute, two seconds, 84 hundredths) you must key in: 0 ENTER (ore)

1 ENTER (minutes)

2 ENTER (seconds)

840 ENTER (thousandths), and NOT 84 ENTER !!!



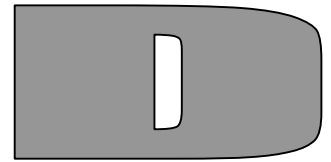

# **SIMPLE STOPWATCH PROGRAM**

## 20SIMPLE STOPWATCH PROGRAM

The basic timing program for Racetime 2 is particularly recommended for all applications for which the simultaneous management of two or more competitors on the race field is not required, or for which there is a single start. The software includes all the main function modes of a normal chronometer (split, sequential, rally). Some particular functions such as the possibility of setting an initial time (start time) and the countdown mode, extend the use of the program to sports events such as riding and carving skiing. The possibility of setting measurement accuracy and output for the displayboard allows it to be used as a possible time marker in team sports.

The basic timing program is selected by pressing **F3** from the program functions selection menu, which can be accessed after accessing Racetime and canceling the memorised data. After program selection, you immediately enter the main menu, from which the various functions available can be selected.

A:Timing  
 B:DispB.pause(s) 8  
 C:Data trans.  
 A B C more

569 570 572 571  
 2 6

A:RACETIME config.  
 B:Disp.Board conf.  
 C:Signal level  
 A B C more

565 566 568 567  
 7.1 7.3 8.1

A:Speedbases length  
 B:Speed unit  
 A B more

573 574 576 575  
 7.2

A:Time calculator  
 B:Battery charge  
 A B menu

577 578 580 579  
 8.2 8.3

Select items with the four function keys

- A. To enter timing mode
- B. To set the duration of the viewing of intermediate times, expressed in seconds, on the displayboard. The duration of the display period can be varied from 1 to 500 seconds.
- C. To access the memorised data transmission function
- F4. To show next menu

Select items with the four function keys:

- A. To access the Racetime configuration menu
- B. Displayboard configuration
- C. To check the efficiency of radio communication (Linkgate transmission system)
- F4. To show next menu

Select items with the four function keys:

- A. To set the speed base length
- B. To set the speed measurement unit
- F4. To show next menu

Select items with the function keys:

- A. Sexagesimal calculator (addition and subtraction of times)
- B. Battery recharge management
- F4. To show next menu



## 21TIMING

```
A:Timing
B:DispB.pause(s) 8
C:Data trans.
A B C menu
```

593 594 59€ 595

```
N 1 0.00
S 0.00
L 0.00
NTst memo ini.T menu
```

589 590 592 591

*Start*

```
N 1 9.89
S 0.00
L 0.00
reset menu
```

585 58€ 588 587

*2 X Start*

```
N 1 1.05.89
S 55.29
L2 12.84
reset menu
```

581 582 584 583

*Or, if the length for speed calculation has been set ...xxx*

```
N 1 L2 1.05.89
S 38.15kmh 55.29
L 39.25kmh 12.84
reset menu
```

597 59€ 600 599

When you select ‘Timing’ with F1, Racetime2 presents a display screen similar to the one shown.

In the first line of the display, the number of the trial (or competitor) and the running time or final time are shown.

In the second line the SPLIT times (times from the start to the impulses subsequently received) are shown.

In the third line the LAP times (difference between two impulses received in succession) appear.

The fourth line as usual shows the options which can be activated with the function keys, in particular:

**F1 (NTst)** : Allows you to set the trial (or competitor) number. Unlike other Racetime 2 programs, the basic timing software does not verify if the number set has already been used or not. It is therefore possible to memorise two or three sequences of times, assigning them the same number.

**F2 (memo)** : Accesses the function for display of times already memorised

**F3 (T.ini)** : Allows you to set initial time (start time)

**F4** : To return to main menu

To start the chronometer, activate the START line (the impulse can be given manually - with the start key - or from the start line, or via the Linkgate radio system).

At each successive START impulse, the chronometer presents the split and acquired intermediate times. A progressive number (1, 2, 3.....) is assigned to the lap number.

The chronometer can be reset at any moment by pressing F1 (reset), and then confirming the operation.

Press F4 to access the main menu (obviously this does not stop the chronometer).

If a reference length for speed calculation has been set, the chronometer presents the lap speed and average speed values. In particular:

- the average speed appears on the split line (second line). (The chronometer automatically calculates the length by multiplying the length set by the number of laps completed)
- the lap speed appears on the lap line (third line).

**Note:** obviously, for speed calculation the chronometer uses the times with the maximum available precision, that is, 1/25000s)

*Ston*

N 1	2.34.56
S	2.34.56
L3	1.38.68
reset ClSto	menu

**601**   **602**   **604**   **603**

When the STOP line is activated, running time stops and the split and lap times are shown.

At this point, when START is activated again the chronometer starts from the point at which it had stopped, and timing restarts as previously described.

Pressing **F1**, on the other hand, annuls the chronometer.

With **F2 (Annul Stop)** the STOP sign is annulled and the time starts running again as if the STOP had never been acquired.

**F4 (menu)** allows you to access the main menu.

**Note:** the LAP line is inactive in the sequence just described (it can be activated without any effect on timing). See par. 2.1 for the particular function of the LAP line in the simple stopwatch.

## 22SETTING INITIAL TIME (START TIME)

N 1	0.00
S	0.00
L1	0.00
NTst memo ini.T menu	

605

606

608

607

N 1	<u>0</u> :00:00.00
S	0.00
L1	0.00

613

614

616

615

N 1	20.00
S	0.00
L1	0.00
Up	Down

609

610

612

611

The start time can be set by selecting T.ini with **F3** when the chronometer is annulled. Confirm each field (hours, min, sec, thousandths) with **ENTER**.

Select whether the chronometer should start from the initial time counting up (as normally) or down.

If 'Back' (**F2**) is chosen, the chronometer will count down to zero and then start to count upwards again. Any SPLIT times acquired while the chronometer is counting down will be displayed and printed with a minus sign.

During the countdown, the **LAP** line (inactive in all other situations) allows you to immediately take the chronometer to 0.000 and to begin the count upwards. On the printer, the value of the counter at the moment of annulment is given, for example:  
RES - 12.78

**Note 1:** with counting down, the displayboard shows the minus sign when the chronometer begins to count upwards again (that is, when it has gone past zero). This display is in conformity with the requirements of Fun-Carving ski competitions. If you wish to eliminate the minus sign on the displayboard, all you have to do is set the first column shown on the displayboard to 1 (instead of 0). This setting should be carried out on the displayboard itself (see the manual for the Microgate alphanumeric displayboard on p. 6).

**Note 2:** LAP times are always calculated as the time which elapses between successive START signals, even if the negative running time is moved to zero through the activation of the LAP line.

## 23 VIEWING OF MEMORISED TIMES

N 1	0.00
S	0.00
L1	0.00
NTst memo ini.T menu	

617

618

620

619

If 'memo' is selected with **F2** when the chronometer is annulled, Racetime 2 shows the times previously memorised.

N 1	(CE=ESC)
S	- 16.25
L1	3.75
←	→ find print

621

622

624

623

With **F1** (←) and **F2** (→), you can run backwards and forwards through the memorised times.

With **F3** the number of a trial/competitor can be accessed.

Press **F4** to print the entire sequence relating to the number of trial/competitor displayed.

To return to timing mode, press CE.

---

## 24 DISPLAY OF TIMES ON THE MICROGATE ALPHANUMERIC DISPLAYBOARD

Check that the Microgate  $\mu$  TAB displayboard is set to 'Program' 0.

The general timing program manages two lines on the displayboards; in particular:

- **Line 0** ('Address' 0) running time is shown (the same as that displayed on the first line of the Racetime 2 display). At each START signal, line 0 stops on split time for a period which can be set according to the user's desires (see par. 1).
- **Line 1** ('Address' 1) displays LAP times; also in this case the length of the display period depends on the value set in the main menu.
- **Line 2** ('Address' 2) shows average speed (only if a reference length has been set)
- **Line 3** ('Address' 3) shows lap speed (only if a reference length has been set)xxxxxx

## 25 DATA TRANSMISSION

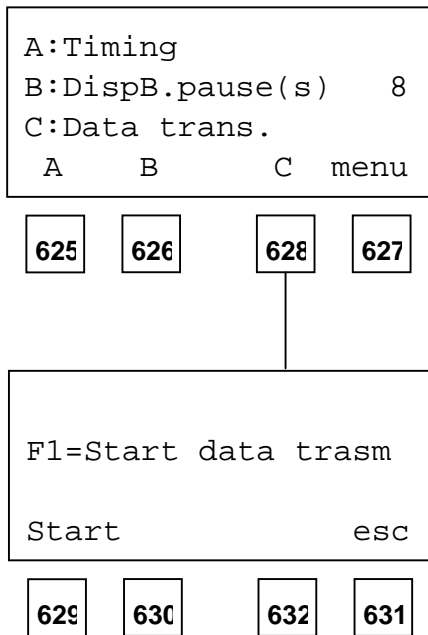

It is possible at all times to transmit the times memorised to a Personal Computer. Select 'C: Data transmission' with F3 from the first screen display of the main menu.

Press F1 to start transmission, F4 to quit.

The data is transmitted in sequence, in the same order in which it was acquired. Only the transmission of net times is possible.

The transmission protocol is given in Appendix B.

The lap times are transmitted as Lap (code 'Info' 3), while the code 'Info' 1 is assigned to Split times.

Lap speeds are marked by the code 'Info' 4, while average speeds bear the code '9'.

# 26SYSTEM CONFIGURATION

## 26.1 RACETIME CONFIGURATION

```
A:RACETIME config.
B:Disp.Board conf.
C:Signal level
A      B      C  more
```

633 634 636 635

```
A:Time rounding
B:Holdoff times
C:LINKGATE Channel
A      B      C  more
```

637 638 640 639  
3.1 3.2 3.3

```
Select rounding
precision
          1/  1/
1s  1/10s 100s 1000s
```

641 642 644 643

```
Start HT = 200 ms
Stop  HT = 200 ms
Lap   HT = 200 ms
AUX   HT = 200 ms
```

645 646 648 647

```
LINKGATE chan.: 0
(S0000000)
(1=ON, 0=OFF)
modify          menu
```

649 650 652 651

Select 'A: Config. RACETIME' from the second screen display of the main menu to access Racetime 2's configuration options.

Remember, however, that if you decide to cancel the configuration when turning on the device, all the parameters will be set at the values normally most suitable in the greater number of cases.

### 26.1.1 Measurement accuracy

select the division in the display of net times from 1 second, 1/10s, 1/100s, 1/1000s.

### 26.1.2 Modifying 'dead' times

allows you to modify the disactivation times of inputs after the acquisition of an event. This can be done separately for the Start, Lap, Stop and AUX lines (the AUX line is only used in the PC On.line mode, see chap. E of manual).

### 26.1.3 LINKGATE channel

allows you to modify the work channel of the LINKGATE system so you can move to another channel if necessary. On the display, the setting for the dip switch located on the LINKGATE Encoder appears. The first selector does not affect channel selection (its function is to select signal length and is therefore shown with the letter 'S'). Next, the status of the other switches is shown (1=switch up, 0=switch down). To modify the setting press 'Edit' (F1). Remember once again that it is absolutely essential that Racetime2 and the

LINKGATE Encoder are set on the same channel (see chap. B).

```

A:Baudrate :    9600
B:Format   :    ASCII

  A      B          more

```

653

654

656

655

```

A:Printer:      On
B:Keyb.beep:   On
C:Initialize Setup
  A      B      C menu

```

657

658

660

659

### 26.1.4 *Setting of serial transmission parameters*

**ATTENTION:** this configuration is only present on versions 20.x.yy, 21.x.yy and 22.x.yy.

Press F1 to modify serial transmission speed (1200, 2400,4800, or 9600 bits/s).

By pressing F2 you can select the format of the data transmitted from binary and ASCII. The transmission protocols for the two modes are given in Appendix B.

### 26.1.5 *Activation/deactivation of the printer and of acoustic signalling when the keys are pressed*

To modify the settings use keys F1 and F2 respectively

### 26.1.6 *Initialization configuration*

when F3 is pressed and the operation subsequently confirmed, all the configuration parameters with the exception of the 'LINKGATE channel' revert to default values.



## 26.2 SETTING THE LENGTH FOR SPEED CALCULATION

```
A:Speedbases length
B:Speed unit

A      B      other
```

**661**   **662**   **664**   **663**

```
Speedbase

Input length (meter)
10.0 (0=no test)
```

**665**   **666**   **668**   **667**

```
Select
Speed unit

m/s  km/h  mph  knot
```

**669**   **670**   **672**   **671**

From the second display of the main menu, select 'A: Speedbases length' with **F1** to insert the reference distance for speed calculation.

The length set must correspond to the distance covered between one time taken and the next. In circuit races, this will typically correspond to the track length.

First insert the meters, up to a maximum 65000, then the centimeters. A value of null indicates that the speed does not need to be calculated.

**Note:** insertion is always possible also later, as Racetime 2 measures only the time taken to cover the base. The speed is calculated at the moment of presentation.

Also from the second display of the main menu, select 'A:Speed unit' with **F2** to select the measurement unit for speed calculation, using the function keys to select from m/s, km/h, mph (land miles per hour) and knots (nautical miles per hour).

## 26.3 DISPLAYBOARD CONFIGURATION

```
A:RACETIME config.
B:Disp.Board conf.
C:Signal level
A      B      C  more
```

673 674 676 675

```
A:Type: Microgate
B:Num.of Disp.B.: 1
C:Advertising Off
A      B      C  menu
```

677 678 680 679

Select 'B: Displayboard config' from the second screen display of the main menu to access displayboard configuration.

### 26.3.1 Displayboard type

ATTENTION: this configuration is present only on versions 20.x.yy, 21.x.yy and 22.x.yy.

Select the type of displayboard that you wish to connect to the Racetime 2 chronometer. Remember that for each displayboard, the appropriate connection cable (obtainable from Microgate) must be used. For connection of the Telecron displayboard, the interface code ACC050 must also be used.

### 26.3.2 Number of displayboards

The number of displayboards controlled by Racetime2 in the basic timing program cannot be changed. See par. 2.3 for the information displayed on the Microgate alphanumeric displayboard.

### 26.3.3 Advertising

If you use a Microgate displayboard, pressing F3 allows you to activate the viewing program (Prog. 1) previously memorised in the displayboard itself. For further information on this subject, see the instructions for the Microgate  $\mu$  TAB displayboard. Pressing again on key F3 disactivates the viewing program and resets the displayboard to the normal program of functioning (Prog. 0).

## 27 OTHER FUNCTIONS

### 27.1 RADIO SIGNAL QUALITY

```
A:RACETIME config.
B:Disp.Board conf.
C:Signal level
  A   B   C  more
```

681 682 684 683

```
Ready to receive !
                                     menu
```

685 686 688 687

*durante la ricezione*

```
Receiving...
  Start
```

689 690 692 691

*dopo la ricezione del segnale*

```
Ready to receive !
  Start
Channel 4      S=100%
CHANNEL DIFF.  menu
```

693 694 696 695

Racetime2's software is equipped with a function for the evaluation of the quality of the radio signal received. This *utility* is especially useful when the radio signal is considerably disturbed and it is therefore necessary to evaluate the transmission's degree of reliability.

Select '**C: Signal quality**' from the second screen display of the main menu and access displayboard configuration. The words 'Ready to receive!' indicate that the system is waiting to receive a radio transmitted impulse. After about 3 seconds from the start of signal reception (during reception 'Reception in progress...' is shown), the channel of the signal received and the quality of the signal as a percentage are shown on the display. Obviously the closer the percentage is to 100%, the better the quality. Values greater than 40% are to be considered 'safe'.

If the channel set on the LINKGATE Encoder (see par. 4.3 and B3.9) does not coincide with the channel set on Racetime2, the message 'DIFF. CHANNEL' (different channel) will appear on the screen. If reception is particularly difficult, several stratagems can be attempted:

- place both the transmitting and receiving radios (the radios connected to the encoder) in an elevated upright position
- if the disturbance is generated by interference from other transmitters operating on the same channel, change the working frequency
- use more efficient antennas (1/4 wave or 5/8 wave, instead of the normal 'charged' type), especially for radios in transmission

**Note:** testing of signal quality should preferably be made with the 'short-long' selector on the Linkgate Encoder (see also the paragraph) set to 'long' (L). If the selector is on 'short' (S), the maximum value indicated by the test is 20%.

## 27.2 TIME CALCULATOR

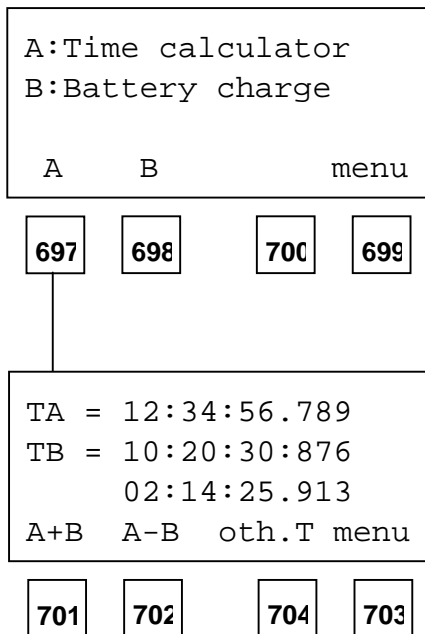

To access the calculator function, select 'A:Calculator' from the third screen display of the main menu.

Enter the first time that you wish to add or subtract (TA): then enter the second time (TB).

Select the operation to be carried out on the two times:

**F1 (A+B)** adds the two times

**F2 (A-B)** subtracts time B from time A

To modify the times, press F3

If only one time must be modified, the time which is to remain unmodified can be 'skipped' by pressing CE, so avoiding pressing ENTER four times.

**Note 1:** the times are normalised at 24.00 hours; for example, 2 :00 .000 + 23 :00 .000 and not 25:00:00.000 !!!

**Note 2:** be careful when entering thousandths, especially if the times to add or subtract are expressed with an accuracy of tenths or hundredths; for example, to insert the time 1 :02.84 (one minute, two seconds, 84 hundredths) you must enter

0 ENTER (hours)

1 ENTER (minutes)

2 ENTER (seconds)

840 ENTER (thousands), and NOT 84 ENTER !!!

### 27.3 RECHARGING BATTERIES

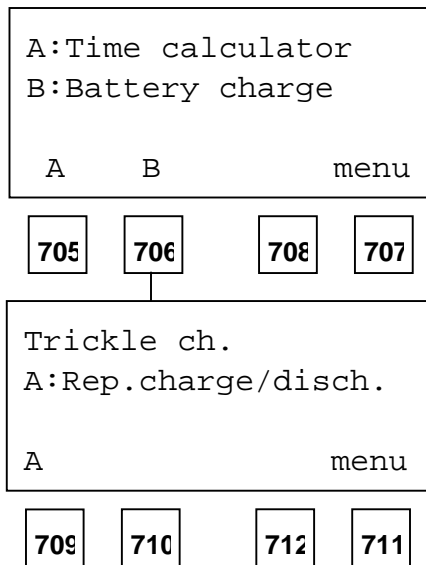

The recharging of Racetime2’s internal batteries is managed entirely by the microprocessor which controls all of the chronometer’s functions. Consequently, it has been possible to implement a recharge control which guarantees maximum battery efficiency at all times, at the same time prolonging the chronometer’s operating life.

To recharge the batteries, connect a 12 - 20 Volt DC power source (normally you will use the AC/DC adapter supplied in Racetime’s kit) to the appropriate power point (chap. A2). If the chronometer is off, information on the current status of the battery recharge management function will be immediately shown on the display.

Specifically, the following messages will appear on the first line of the display::

Status/messagge	Function description	LED status
Maintenance	the chronometer is supplied by an external power source and, concurrently, the batteries’ efficiency is maintained by a weak recharge current	Brief blinking every four seconds
Discharge	at the beginning of a recharge cycle, the batteries are completely run down before being recharged	LED continuously lit
Recharge	recharge in progress. On the first line of the display, the time still to go until the end of recharge is shown.	Blinking LED

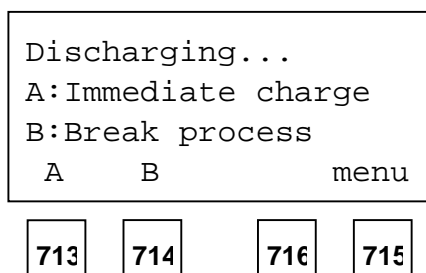

If you see the letters “Vext. Ins” blinking on the first line of the display, this means that the voltage supplied at the recharge/supply input is insufficient. ATTENTION : when external power is insufficient, recharging is interrupted and so cannot be completed correctly and within the time anticipated.

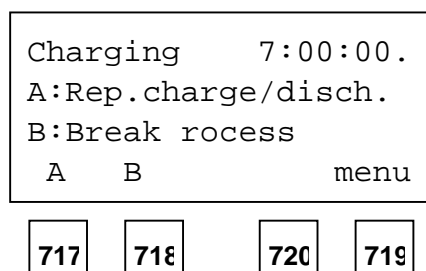

If the chronometer is in ‘Maintenance’, press ‘A: Rep.charge/disch.’ (F1) to begin a new charge cycle. This will start battery discharge. The duration of this discharge phase is variable and depends on how fully the batteries are charged. (The time needed to discharge can last up to four hours).

After discharging the batteries, Racetime2 will automatically begin to recharge; this takes seven hours.

After recharging, the words ‘End Charge – OK’ indicate that the process has been correctly completed. If, however, battery malfunction has caused premature interruption of charging, the messages ‘Err. Batteries – LV’ (insufficient battery voltage) or ‘Err. Batteries –HV’ (battery voltage too high) will appear. During recharging the time needed to complete the process will appear on the display.

During discharging, it is possible at any time to go straight over to charging by pressing ‘A: Rep. charge/disch. (F1). This will shorten the time needed for recharging. However, you are advised not to charge the batteries without first discharging them as this could cause a reduction in the capacity of the batteries (memory effect).

At any moment, you can interrupt discharging/recharging by pressing ‘B: Break process’ (F2).

**Note 1:** If the external power source is cut off during charging, charging will be interrupted and resumed from the same point it had reached before being interrupted when the power source has been restored. This represents an extra guarantee of the reliability of the recharge system.

**Note 2:** During discharging and recharging, Racetime2 becomes slightly but noticeably warm. This is absolutely normal.

It is also possible to access these functions when the chronometer is on. In this way, you can begin to recharge the device without interrupting a timing session.

To access recharge management, choose ‘A: Battery charge’ from the fourth screen display of the main menu.

### 27.3.1 Low batteries warning

When the batteries have nearly run down completely and an external power source is not connected, the LED lights up and remains lighted. From the time the LED lights up, you still have a considerable amount of time to finish your work, nearly two hours without using the printer (but much less if the printer is used frequently). If it is not possible to quickly connect the chronometer to an external power source, it might be better to disconnect the printer (see par. C8.10) in order to increase remaining autonomous functioning.

Remember that when fully charged the batteries can be used continuously for approximately 8-9 hours, if on average a printout is made every 20 seconds. Length of duration may be less in particularly harsh climatic conditions or if the batteries are worn out. It is absolutely normal for battery efficiency to decline after approximately 500-1000 recharge cycles. If you notice a significant reduction in the duration of the batteries, please contact Microgate for replacements.

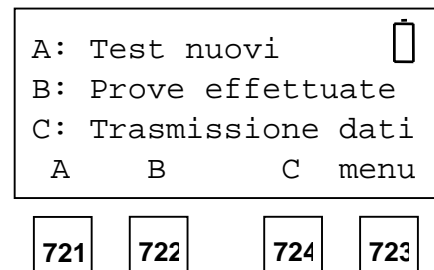

NOTES

---

---

---

---

---

---

---

---

---

---

---

---

---

---

---

---

---

---

---

---

---

---

---

---

---





**APX**

**APPENDIX**

## 28 TECHNICAL DATA

### RACETIME2

Weight	595g, including batteries (chronometer: 420g, printer: 175g)
Dimensions	245 x 114 x 57 mm (l x w x h) (chronometer: 170 x 90 x 47 mm, printer 120 x 114 x 57 mm)
Unit of measure	Time: selectable 1s - 1/10s - 1/100s - 1/1000s; speed: selectable m/s - km/h Mph - knots
Resolution measure	4 x 10 <sup>-5</sup> s(1/25000s)
Display	Alphanumeric display, 4 lines of 20 characters each - Character dimension: 5 x 3 mm
Time base	12.8mhz Quartz, stability ± 10ppm between -25° and +50°C
Precision	±0.85 s/day for external temperatures between -25° and +50°C
Usage temperature	-25° / +70°C
Power supply	Internal NiCd batteries; externally supplied c.c. 9-20V
Battery recharge	Intelligent recharging device incorporated (automatic discharge/recharge after checking charge)
Autonomy	>7 hours with average print rate of 1 every 20 seconds
Elaboration unit	C-MOS 16 bit microprocessor
Printer	Removable, on impact - 16 characters per line - speed: approx. 1 line/s functions with normal paper
Keyboard	Start-Stop-Lap keys - Numerical keys - 4 function keys - 4 control keys Key to disable inputs
Memory	Approx. 1350 chronometric events - Maintains memorised data also when turned off
Connections	Connections to polifunctional 15 pole plug:

- Start, Stop, Lap and Auxiliary signal inputs
- Output +5V stabilised for external device power supply
- Serial input/output RS 232 for connection with alphanumeric displayboards and PC
- Penta-polar plug to connect Microgate's LINKGATE radio transmission system
- Input for external power source and/or battery recharger
- 3 analog inputs for connection of air, humidity and snow temperature probes

## LINKGATE ENCODER

Weight	110 g
Dimensions	110 x 50 x 27 mm (l x w x h)
Transmission mode	FSK digital transmission; redundancy code with information correctness verification and auto-correction Transmission channelization (127 selectable channels)
Impulse transmission acc.	± 0.4 ms
Velocity resolution meas.	1.22 *10 <sup>-4</sup> s (1/8192s)
Time base	Real Time Clock with quartz from 32768 Hz digitally compensated Quartz from 4 MHz ±10 ppm between -25° and +50°C
Precision	± 0.85 s/day for external temperatures between -25° and +50°C
Usage temperature	-25° / +70°C
Power supply	3.6 V 120mAh Lithium batteries
Autonomy	Approx. 6 years at average use rate of 50 events/day
Elaboration unit	C-MOS 8 bit microprocessor
Keys and controls	Signal, Repeat, Modem and second function keys Rotating selector with 16 positions for type of signal transmitted (Start, Stop, Lap 1....14) Dip Switch to select long/short signal Dip Switch to select transmission channel Internal dip switch to allow interfacing to various transceivers
Memory	256 times and 256 speeds
Radio interfacing	Possibility of connecting various types of VHF or UHF transceiver, using various cables available and setting <b>machine's internal dip switch correctly</b>
Connections	Input signal to Ø4mm plug for a normally open contact Auxiliary input to Ø4mm plug to obtain speeds (contact normally open) Modem input to Ø4mm plug (accepts RS232 levels or TTL) 5 pole connector for BF signal transceivers, PTT activation (galvanically insulated output), serial output for data transfer ( <b>galvanically insulated output</b> )

## LINKGATE DECODER

Weight	Decoder 120g
Dimensions	Decoder: 65 x 50 x 30 mm (l x w x h)
Reception mode	Decodifies FSK
Time base	4 Mhz Quarz
Usage temperature	-25° / +70°C
Power supply	5 Vcc, directly supplied by chronometer
Controls	Internal dip switch for adjustment of input level according to transceiver used and for enabling of internal loudspeaker
Radio interfacing	Possibility of connecting VHF or UHF transceivers of various types
Connections	3 pole connector to connect to BF transceiver output Cable with 5 pole connector to connect to chronometer

## 29 Racetime2 transmission protocol

### 2.1 BINARY TRANSMISSION

The data is transferred in binary format, in order to obtain more efficient compacting of data. The Header and the Epilogue are present in off-line transmissions but are not transmitted during functioning in 'PC ON-LINE' mode.

The following 'character types' refer to the length of the data:

*char* 1 byte (8 bit)  
*integer* 2 bytes  
*long integer* 4 bytes

**SERIAL PORT SETTING:** No parity, 8 data bit, 1 stop bit. Standard transmission velocity is 1200 bit/s. It can be set to 1200, 2400, 4800, 9600 bit/s.

<u>Description</u>	<u>N° and character type</u>	<u>N° bytes</u>	<u>ASCII code</u>	<u>Notes</u>
<b>Header</b>				
STX	1, char	1	02h	Start of Text
Program Code	10, char	10		'R2' followed by 8 spaces
CR	1, char	1	0dh	Carriage return
LOOP START (AND ON-LINE START)				
<b>PROGRESSIVE COUNTER</b>	1, char	2		Starts at 1 In the PC On-Line mode it is the event counter for the event type. During transmission repetition in PC On-Line mode it is always equal to 65535
<b>N° START</b>	1, char	2		<=65535, starts from 1 In PC-OnLine mode, it is the global event counter
<b>RUN</b>	1, char	1		<=255, starts from 1
<b>PHYSICAL CHANNEL</b>	1, char	1		0=start, 255=stop, 1..253=lap 254=aux ***
<b>LOGICAL CHANNEL</b>	1, char	1		0=start, 255=stop, 1..253=lap (lap no.) 254=aux
<b>INFO</b>	1, char	1		0=Event time 1=Run net time (split) 2=Total net time (split) 3=Lap net time 4=Speed 5=Speed time 6=Air temperature 7=Snow temperature 8=Humidity 9=Average speed (not radio) 10=NF (non-finisher) 11=DS (disqualified) 12=NS (non-starter) 20=annulled 21=skipped not yet assigned

				22=skipped already assigned 99=control time in the PC On-Line mode
<b>SIGNAL ORIGIN</b>	1, char	1		R = radio M = manual or from input K = manually modified event time A = automatic start
<b>SIGN</b>	1, char	1		E = received by cable from Linkgate Encoder (download of event times after time interval)
<b>TIME</b>	1, long integer	4		in the simple chronometer mode is equal to 1 if split time is negative time in 1/25000 s * · **
<b>CR</b>	1, char	1	0Dh	Carriage return
<i>LOOP END ( AND ON-LINE END)</i>	<b>car. subtotal</b>	<b>15 (loop)</b>		
<i>EPILOGUE</i>				
<b>EXT</b>	1, char	1	03h	End of Text
<b>CHECKSUM</b>	1, char	1		(Σascii) module 128

NOTE :

\* For the transmission of fixed point data (humidity, temperature, speeds), 2 integers are transmitted. The first represents the whole number (to the left of the decimal point) and the second the decimal part (to the right of the decimal point). Example: -15.44 is transmitted as 65521 (that is, -15) and 44.

Climatic data are expressed as follows:

- first primo integer: always nill

- temperatures are transmitted on the second integer, tenths of a degree, as a signed value. For example, -15.1° is transmitted as -151, that is, 65385

- humidity is always transmitted on the second integer, as a percentage (so 12%UR is transmitted as 12)

\*\* Event times are sent with maximum accuracy; net times are sent with the accuracy set in the relative configuration menu

\*\*\* For events teletransmitted via radio, the field contains the signal type (Start, Lap 1...14 or Stop)

## 29.1 ASCII TRANSMISSION

The data is transferred in ASCII format (only values < 127 (7Fh)).

The *Header* and the *Epilogue* are present in off-line transmissions but are not transmitted during functioning in 'PC ON-LINE' mode.

**SERIAL PORT SETTING:** No parity, 8 data bit, 1 stop bit. Standard transmission velocity is 1200 bit/s. It can be set to 1200, 2400, 4800, 9600 bit/s.

<u>Description</u>	<u>N°</u>	<u>ASCII (Dec, Hex)</u>	<u>Notes</u>
<b>Header</b>			
STX	1	2,02h	Start of Text
Program Code spaces	10		'R2' followed by 8 spaces
CR	1	13,0Dh	Carriage Return
Loop start (and on-line start) Consecutive counter	4		Starts at 1 In the PC On-line mode it is The event counter for the Event typer. During Transmission repetition In PC On-line mode it is Always equal to 65535 <=65535, starts from 1 In PC—Online mode, it is The global event counter <=255, starts from 1
Start N°	4		000=start, 255=stop, 1..253=lap 254=aux ***
Run Physical channel	3		0=start, 255=stop, 1..253=lap (lap. no.) 254=aux
Logical channel	3		0=Event time 1=Run net time (split) 2=Total net time (split) 3=Lap net time 4=Speed 5=Speed time 6=Air temperature 7=Snow temperature 8=Humidity 9=Average Speed (non radio)
Info	1	48,30h 49,31h 50,32h 51,33h 52,34h 53,35h 54,36h 55,37h 56,38h 57,39h  65,41h 81,51h 80,50h 97,61h 83,53h  115,73h  90,5Ah	0=Event time 1=Run net time (split) 2=Total net time (split) 3=Lap net time 4=Speed 5=Speed time 6=Air temperature 7=Snow temperature 8=Humidity 9=Average Speed (non radio) A=NF (non finisher) Q=SQ (squalified) P=NS (non starter) a=annulled S=skipped not yet assigned s=skipped already assigned Z =control time in the PC-Online mode

<b>Description</b>	<b>N°</b>	<b>ASCII (Dec, Hex)</b>	<b>Note</b>
Signal origin	1	82,52h 77,4Dh 82,52h  65,41h 69,45h	R = radio M = manual or from the input K = manually modified event time A = automatic start E = received by cable from Encoder Linkgate (download event times after interval of time)
Sign	1		In simple stopwatch mode, is equal to '1' if the split time is 'negative'
Time	9		Time in 1/25000 s *,**
CR	1	13,0Dh	Carriage Return
<b>loop end (and on line end) car subtotal.</b>		<b>29 (loop)</b>	
<b>Epilogue</b>			
ETX	1	3,03h	End of Text
Checksum	1		( $\Sigma$ ascii) module 128

## NOTES :

\* When fixed-point data is transmitted (humidity, temperature, speed), the transmission format is as follows:

data with positive sign: 00000.000

data with negative sign: -0000.000

\*\* Time events are sent with maximum precision whereas net times are transmitted with the precision set in the relative configuration menu and padded with zeros.

\*\*\* For events teletransmitted via radio, the field contains the signal type (Start, Lap 1..14 or Stop).

## 29.2 ON-LINE TRANSMISSION DURING TIMING

The data is transformed into ASCII format (only values < 127 (7Fh))

**SERIAL PORT SETTING:** No parity, 8 data bit, 1 stop bit. Standard transmission velocity is 2400 bit/s.

<b>Description</b>	<b>N°</b>	<b>ASCII (Dec, Hex)</b>	<b>Notes</b>
Start N°	3		<=999, starts from 1 Aligned to the right. Non-significant positions are the spaces for net times and zeros for time events
Info	1		Type of information sent: '.' (point): running time ' ' (space): net time '0' (zero): time event 'a': annulment 'r': substitution 's': skipped 'K': manual correction 'P': not started 'A': not finished
Space	1		Reserved for future uses
Type of signal	3		000 = Start 255 = Stop xxx = Intermediate nr.
Time	12		Format HH:MM:SS.dcm The non-significant positions to the left are spaces for net times and zeros for time events.
Spaces	2		Reserved for future uses
CR	1	13,0Dh	Carriage Return
Total char.	23		



## 30 Data format for the transfer of data stored in the Linkgate Encoder

The data download protocol consists of a Header containing 10 characters and the actual data (9 characters) organized in n record (where n is the number of impulses).

### 30.1 HEADER

Byte progressive N°	Description	Content
1	Initial Header Code	0xAA
2	Linkgate Channel	0..127 Dec
3	Signal type	0x00 Start 0x01..0x0E Lap 0x0F Stop
4	Transmission start time	Time_LL
5	(in 1/32768 di sec)	Time_LH
6		Time_HL
7		Time_HH
8	Internal Code	0x77
9	Internal Code	0xBA
10	Internal Code	0x31

### 30.2 DATA FRAME

Byte progressive N°	Description	Contents
11	Initial frame code	0xAA
12	Chronological impulse	Time_LL
13	(in 1/32768 di sec)	Time_LH
14		Time_HL
15		Time_HH
16	Speed value in 1/8192 Of a second	Speed_Low
17		Speed_High

### 30.3 SERIAL PORT SETTING

1200 baud, NO parity, 8 data bit, 1 stop bit

## 31 PROBLEMS AND REMEDIES

Problem	Probable Cause	Remedy
When Racetime is turned on, nothing appears on the display	batteries flat	connect power source/battery charger
The start/lap time/stop impulses are not being received via radio	<p>the radio connected to Racetime 2 is off or the volume is too low</p> <p>the radio is not receiving</p> <p>the plug which connects the Linkgate Encoder to the radio is not inserted correctly</p> <p>Linkgate Decoder is not connected to Racetime2</p> <p>the LCK key has been pressed and so the line is blocked</p>	<p>turn on the radio and set the volume at approximately <math>\frac{3}{4}</math></p> <p>check that the radios are operating on the same frequency</p> <p>check that radio connected to Linkgate Encoder is on</p> <p>check that the plug is inserted correctly</p> <p>connect Linkgate Decoder to Racetime 2</p> <p>check to see whether the symbol # appears on the second line of the display. If it does, deactivate the block by pressing LCK again</p>
Radio reception does not work well (impulse loss)	<p>bad positioning of the transmitting and/or receiving radio, transmitter and receiver too far from one another</p> <p>disturbance generated by other transceivers operating on the same or adjacent frequencies</p>	<p>look for a better position (sometimes small changes of position can greatly improve reception), keep the antennas vertical, replace the antennas with a higher reception performance type (1/4 wave, 5/8 wave)</p> <p>if possible, try a different frequency</p>
The photocell is connected but impulses are not being received	bad alignment of photocell	align the photocell correctly and check that it is functioning correctly
On receiving a start impulse, the chronometer does not start	the 'Automatic finish search' function is not enabled so the start is received and memorised but the running time does not start automatically	from the 'Racetime Configuration' menu, enable 'Automatic finish search'
The finish or lap impulses do not stop the chronometer	the 'Automatic Skip' function is activated	deactivate 'Automatic skip'
During a race a competitor can no longer be seen and cannot be called up on the display	the competitor's time has exceeded the set 'Maximum Time'	modify the setting for maximum time according to requirements. If necessary, disable the function (set 00:00:00:000)

**MICRO  GATE**

Microgate S.r.l.  
Via Stradivari, 4  
I-39100 BOLZANO - ITALY  
Tel. ++39-0471-28.85.45 - Fax ++39-0471-28.17.60  
<http://www.microgate.it>

**MICRO  GATE**